

COLLEGE MAGAZINE

DYNAMICS 2025

VOLUME 12



ATME COLLEGE OF ENGINEERING

Board of Trustees



Arun Kumar L
Chairman

Shivashankar K
Secretary

Veeresh R
Treasurer

Venkatesh H
Trustee

**Dhirendra
Kumar R Mehta**
Trustee

**Mallikarjunappa
KR**
Trustee

Nooreain
Trustee



Governing Council

Sri. Arunkumar L
Chairman

Members

Sri. Shivashankar K
Sri. Veeresh R
Sri. Venkatesh H
Sri. K R Mallikarjunappa
Sri. Dhirendra Kumar R Mehta
Dr. Syed Shakeeb Ur-Rahman
Dr. Chidananda Gowda K
Sri. S R Mahesh
Dr. Sham Vasudev Rao
Dr. Bhagyashree S R

VTU Nominee

Dr. N Krishne Gowda

Member Secretary

Dr. Basavaraj L
Principal, ATMECE



YANTRA – Yugantar for Advancing New Technology, Research & Acceleration

Introduction

Main Purpose The core purpose of YANTRA, the official theme for National Technology Day 2025, is to drive a transformational shift in India’s science and technology landscape—from being a technology adopter to becoming a global leader in innovation and deep-tech research. The initiative aims to build a strong, future-ready ecosystem by accelerating the development and deployment of advanced technologies across sectors such as AI, quantum computing, clean energy, precision manufacturing, biotech, and space-tech. Through YANTRA, the Indian government emphasizes the need for systemic synergy—bringing together policy makers, research institutions, industry, and startups—to ensure scientific discoveries translate into real-world applications that address national challenges. The purpose is also to foster innovation that is scalable, inclusive, and sustainable, aligned with national visions like Atmanirbhar Bharat (self-reliant India) and Viksit Bharat 2047 (developed India).

The Technology Development Board (TDB), under the Department of Science and Technology (DST), Government of India, today unveiled the official theme for National Technology Day 2025 — “YANTRA – Yugantar for Advancing New Technology, Research & Acceleration.”

TDB-DST launches theme for National Technology Day 2025

The word YANTRA, deeply rooted in India’s scientific and cultural heritage, represents not just mechanical ingenuity but also symbolic power — of systems, synergy, and scalable solutions. Yugantar, meaning an epochal shift, is emblematic of the country's momentum in transitioning from technology adaptation to global technology leadership.

National Technology Day commemorates the momentous events of 11th May 1998, when India conducted successful nuclear tests under Operation Shakti, and saw the maiden flight of the indigenously developed Hansa-3 aircraft. In recognition of these achievements, then Prime Minister Sh. Atal Bihari Vajpayee declared 11th May as National Technology Day.

Over the years, National Technology Day has evolved into a flagship occasion for honouring scientific excellence, showcasing industrial innovations, and reinforcing the partnership between science, society, and industry. This year's celebrations will be held on 11th May 2025 under the aegis of TDB-DST. The event will bring together policymakers, scientists, technocrats, industry leaders, academic institutions, and startup founders to deliberate on accelerating India's technological journey through deep-tech, precision engineering, and transformative R&D.

India's National Technology Day, observed annually on May 11, commemorates pivotal milestones such as the 1998 Pokhran-II nuclear tests, the maiden flight of the indigenous Hansa-3 aircraft, and successful trial of the Trishul missile.



Established by Prime Minister Atal Bihari Vajpayee, the day has evolved into a flagship platform celebrating scientific excellence, innovation, and the synergy between academia, industry, and government. In 2025, the Technology Development Board (TDB) under the Department of Science & Technology (DST) unveiled the official theme: "YANTRA – Yugantar for Advancing New Technology, Research & Acceleration". The choice reflects India's ambition to transition from technology adoption to global leadership through scalable, sustainable, and systemic innovation.

The Sanskrit-derived term "YANTRA" extends beyond a mere machine—it symbolizes systems thinking, synergy, and scalable solutions, deeply rooted in India's scientific and cultural heritage.

Yugantar, translating to "epochal shift", captures the essence of India's ambition—not just incremental growth, but a transformational leap in innovation and technology leadership on a global scale. Together, they project a narrative of systemic strength powered by integrated institutions and pioneering research.



The YANTRA theme aligns with India's broader goals of Atmanirbhar Bharat (self-reliant India) and Viksit Bharat 2047 (developed nation by India's centenary), aiming to harness innovation for inclusive, sustainable growth. The vision: foster deep-tech ecosystems that convert laboratory research into impactful solutions, catalyze precision manufacturing, accelerate technology commercialization, and enhance national resilience. Central to this ambition is the Innovation Triad—a dynamic collaboration between government, R&D institutions/academia, and industry—which, when synergized with India's vibrant start-up ecosystem (now among the top globally), becomes the engine of transformative change.

Under YANTRA, the spotlight is on strategic sectors where India strives to lead: Next-generation manufacturing and robotics, driving automation, efficiency, and precision in industry. Space and defence technologies to reinforce strategic autonomy and innovation, inspired by historical milestones like the Trishul missile and Hansa-3 aircraft. Clean energy and sustainability-driven innovations fueling India's green transition and climate resilience. Healthcare, biotech, AI, and quantum computing, representing cutting-edge R&D frontiers tackling societal challenges and enabling global competitiveness. Platform initiatives include panel discussions, awards for innovators, exhibitions of breakthrough technologies, and collaborative dialogues aimed at bridging policy, academia, and industry.

National Technology Day 2025 under the YANTRA banner is not merely ceremonial—it is strategic. It reaffirms India's commitment to innovation-led growth, emphasizes the urgency of building advanced technology capability (from semiconductors to AI-powered systems), and highlights how youth, entrepreneurship, and digital infrastructure can propel national progress. As voices from industry point out—such as Deloitte's Gaurav Shukla stressing cyber resilience, and Tata's leadership urging smart, sustainable innovation—the narrative is clear: technology must empower, protect, and uplift. YANTRA stands as a clarion call to realize India's potential as a global technological leader, shaping not just national destiny but the future of global innovation.



MESSAGE FROM CHAIRMAN

Mr. Arun Kumar L
Chairman



MESSAGE FROM PRINCIPAL



Dr. Basavaraj L Principal

Dear Students,

ATMECE has emerged as a prominent institute offering quality engineering education. All round continuous constructive changes in infrastructure and academic standards have helped us to build a brand name. We are able to achieve an enviable position due to the concerted efforts by the committed students, dedicated staffs and caring pragmatic management. On behalf of Management and everyone, I wholeheartedly thank the editorial team of “Dynamics” for their untiring efforts in bringing out “**Dynamics 2025**”. I wish the readers a happy reading.

Dr Basavaraj L
Principal, ATMECE

CONTENT



Editorial Desk	1
Department Reports	2 - 105
Women Cell Activity	106 - 109
Articles	110 - 139
ATMEya 2025 Glimpses	140 - 143
Photography & Sketches	144 - 153
Alumni Voice	154 - 157

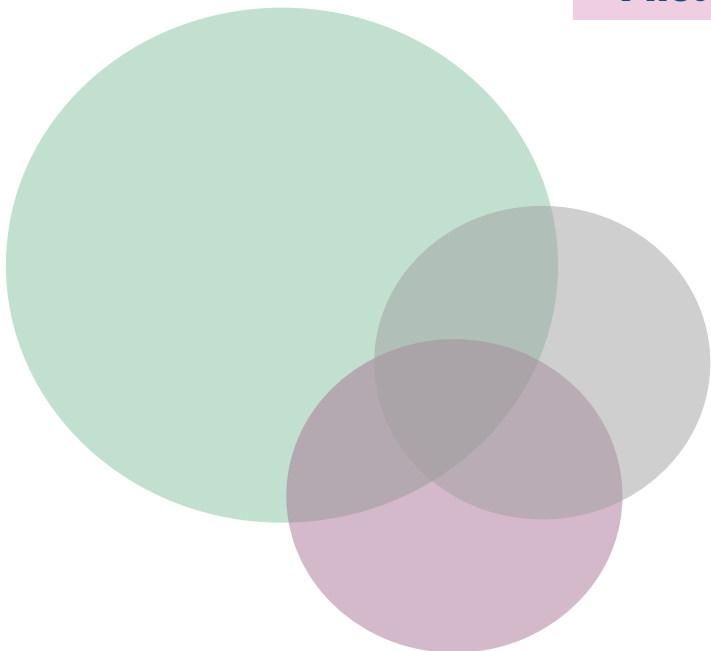



Message from Editorial Team

As the summer sun glows pleasantly to heat up everything, the creativity and talent in every techie of ATMECE is thirsty to project his/her talents and skills. On behalf of editorial board, proudly presenting 12th issue of “DYNAMICS” designed with the a vision of quench the thirst by layering a platform for innovative ideas. The soul of creativity lies in the dream to unveil inherent talent. The power of this dream fueled us forward and made “DYNAMICS”, a reality.

We are thankful to all who contributed to fulfill our dream. First and foremost let me thank our Chairman Sri. Arun Kumar L, who was always with us, to provide a wonderful platform to nourish the talents. I extend my sincere thanks to Management and our Principal who always in the forefront to encourage and inspire to execute wonderful ideas. The support of all Heads of the department cannot be forgotten and I thank each one for deputing the right coordinators. It would be totally unfair if I am not mentioning the effort of editorial team who dreamt together to bring our 12th issue of “DYNAMICS” I thank all students and faculty coordinators for their overwhelming support.

I thank Mr. Nagappa T N, programmer for his design work. I also wish all outgoing students of 2025 a bright future ahead. I would like to conclude by quoting a few words of Robin S. Sharma “We are all here for some special reason. Stop being a prisoner of your past. Become the architect of your future”

Sincerely,

The Editorial Team

Editorial Committee

Chairman

Dr Basavaraj L, *Principal*

Chief Editor

Dr. Puttegowda D, *HOD, CSE*

Coordinators

Mr. Anjan Kumar J, *Dept of BSH*

Mr. Raghu, *Dept of ME*

Dr. Praveen Kumar, *Dept of EEE*

Mrs. Namitha, *Dept of CV*

Mrs. Madhurya B Eshwar, *Dept of ECE*

Dr. Anilkumar C J, *Dept of AIML*

Dr. Anitha D B, *Dept of CSE(Data Science)*

Dr. Nasreen Fathima, *Dept of CSE(Cyber Security & CSD)*

Dr. Oscar Abhishek, *Dept of MBA*

Dr. Pavithra M S, *Dept of MCA*

Mrs. Ashwini P, *Dept of CSE*

Mr. Rakesh, *Dept of CSE*

Mr. Nagappa T N, *Dept of CSE*

DEPARTMENT OF CSE – ARTIFICIAL INTELLIGENCE & MACHINE LEARNING

Department of CSE – Artificial Intelligence & Machine Learning

About the Department

The Department of AIML at ATMECE is dedicated to impart constructive and quality technical education with high standards at undergraduate level. The faculty members of the department are committed to make our students by providing the expertise and proficiency in Artificial Intelligence and Machine Learning to tackle the issues of societies. Department is well equipped with all modern computing facilities to meet the academic and industrial requirements. AIML can be used to create computer programs that mimic human conversation. AIML can also be used to create virtual assistants, which are computer programs that can perform tasks such as scheduling appointments and sending emails. Additionally, AIML can be used to create educational software, which can be used to teach people about topics such as history or science.

The objective of the program is to provide an experiential learning opportunities such as hands-on experience and project-based learning, indulge in research projects, and internships which provide a strong foundation to work across the globe.

We at ATMECE more prominence is placed on elevating the students learning experience by providing value-added courses, skill-enhancement programs, and motivate students to participate in technical symposiums, hackathons organized by premier institutes across the nation. The students, faculty, and staff of AIML at ATMECE, we believe in teamwork, we inspire, encourage each other, we help each other, and, most importantly, we trust each other. This is the key to make our students success at AIML program at ATMECE. To bring the success and laurels to the department we focus more on constructive engagements which will enable employment opportunities to our students.

Department of Artificial Intelligence & Machine Learning at ATMECE is stalwartly prepared to face the new societal issues and challenges in this new IT era with Indian Talent (IT). We hope and assure that we transform our students in all dimensions of their student life to become better citizen of this nation for better India and better world.

Vision of the Department

- To impart technical education in the field of Artificial intelligence and machine learning of top-notch quality with a high level of professional competence, social obligation, and global cognizance among the students.



Mission of the Department

- To impart technical education that is up to date, relevant and makes students to compete at global level
- Fostering an ambiance where students can adopt the suitable moral, intellectual, emotional, and physical attributes to shine as the leaders of tomorrow's society
- To strive to meet ever higher educational standard

Activities organized in the department:

1. Department of CSE(AI&ML) in association with department of CSE organized a 3 day FDP on “Artificial Intelligence, machine Learning and Deep Learning in the Data Revolution Era: Progress and Applications”, from 03-02-2025 to 05-02-2025 at ATMECE, Mysuru.
2. Department of CSE(AI&ML) in association with Dean research office organized a “Technical talk on "Revolutionizing Semiconductor IC Design with Cutting-Edge AI & ML" by Mr. Laxmanan, Committee Member of IET Bangalore Network and Technologist & SMTS at Texas Instruments”, on 14-02-2025 for Students of 3rd and 5th Semester of all branches



3. Students of 5th semester Amruta Salagare, Hemanth Kumar C S, Reem K and Vandana H Participated in 24hr Hackathon "CODE BATTLE 2K25" - at KLS Vishwanathrao Deshpande Institute of Technology, Haliyal on 11/03/25 and 12/03/25 and won Second Prize.
4. Department of CSE(AI&ML) organized a two-day workshop in collaboration with NVIDIA for 5th semester students on "Building LLMs with Prompt Engineering", 5th and 6th May 2025 at ATMECE, Mysuru.
5. Department of CSE(AI&ML) organized a technical talk on "Biology for Engineers and Technology" on 23-04-2025,
6. Department of CSE(AI&ML) in association with Dean research office, ATMECE and IET-On Campus ATME student chapter organized one-day Technical workshop on "Low code / No Code AI" on 26th April 2025 at ATMECE, Mysuru.

Faculty List			
Sl.No.	Name	Qualification	Designation
1	Dr. Anil Kumar C J	BE, M.Tech, Ph.D	Associate Professor and head
2	Dr. Hussana Johar R B	BE, M.Tech, Ph.D	Associate Professor
3	Dr. Uma Mahesh R N	BE, M.Tech, Ph.D	Associate Professor
4	Mrs. Khateeja Ambareen	BE,M.Tech,(Ph.D)	Assistant Professor
5	Mrs. Vanitha G Nayak	BE,M.Tech	Assistant Professor

Technical Staff List			
Sl.No.	Name	Qualification	Designation
1	Mr. Manjunath H	BE	Instructor
2	Ms. Geetha B	BE	Instructor

Supporting Staff List			
Sl.No.	Name	Qualification	Designation
1	Mr. Basavaraju K N	ITI	Lab Assistant

Academic Toppers		
8th Semester	5th Semester	3rd Semester
Bhavana S P Yashaswini S Manushree	Dhakshat Reem K Syed Farhaan	Niveditha K Shoaib Siddiq Ayaan Shaikh

DEPARTMENT OF BASIC SCIENCE

Department of Chemistry

“ The country which is in advance of the rest of the world in chemistry will also be foremost in wealth and in general prosperity.”

- WILLIAM RAMSAY

The Department of Chemistry welcomes both students who want to learn the principles of chemistry and those who want to pursue professional careers in the subject. Chemistry is deeply intertwined with all aspects of human activity (food, clothes, housing, transportation, health, and so on), and comprehending its language is critical for addressing present and future social and economic concerns. Chemistry is a distinct academic discipline as well as an industry. Future engineers and researchers can thus pursue careers in any chemistry-related field, such as pharmaceuticals, clinical, synthetic, and biological compound analysis, materials for converting and storing solar energy, pollutant analysis and chemical analysis procedures for the environment, and new communications and information technologies about materials and electrical components.

The Department of Chemistry at ATME College of Engineering offers both theoretical and practical disciplines. Chemistry is basic in the studies of Engineering and technology. The Department has close cooperation with disciplines in all branches of Engineering. The Department of Chemistry is well known for its excellence in teaching and research. The faculty members of the department are well qualified and engaged in state-of-the-art research as well as guiding the Engineering and Ph.D. Students.

The Department of Chemistry at ATME College of Engineering has Research articles published in Scopus-indexed international journals. The faculties in the department are actively involved in educational, research, cultural, sports, and promotional activities.

About the Research Centre

The Department of Chemistry obtained the status of the research center in the year 2014 with two eligible research guides Dr. Avinash. K, Dr. Halligudra Guddappa & Dr. Chaitra T K. Presently one student is awarded, and two students are working as full-time research scholars at the research center.

The lab is provided for wet lab operation and a separate working place for dry lab. Both places are well equipped with working tables, Wi-Fi internet, and other facilities such as glassware and numerous chemicals for the smooth conduct of experiments. Students and research Scholars are provided access to various journals like Elsevier, Springer, Taylor & Francis, and many more.

The research lab is equipped with many sophisticated Equipment that are listed below.

- Single beam UV-Visible Spectrophotometer & Visible Spectrophotometer
- Rota vacuum Evaporator
- Muffle furnace with a temperature range of 500 °C - 1500 °C
- BOD incubator 0 °C - 100 °C, Microbiological incubator 0 °C - 60 °C.
- Hot air oven up to 400 °C,
- Laminar airflow
- Sonication bath
- Four digit weighing balance
- UV chamber
- Autoclave
- Centrifuge
- Magnetic stirrers
- Hot plates.
- Distilled water plant.
- Microwave oven

Faculty List			
Sl.No.	Name	Designation	Experience
1	Dr. Avinash K	Assistant Professor & Head	18 Years
2	Dr. Halligudra Guddappa	Assistant Professor & Researcher	9 Years
3	Dr. Chaitra T K	Assistant Professor	7 Years
4	Mr. Mahendrakumar H S	Assistant Professor	8 Years
5	Mr. Thejas Gowda B	Assistant Professor	1 Year
6	Ms. Tejaswini B M	Assistant Professor	1 Year

Supporting Staff			
Sl.No.	Name	Designation	Experience
1	Mr. Nandan Gowda J T	Lab Instructor	1 Year
2	Mr. Lakshmana G N	Attender	15 Years

Department of Mathematics

“An equation for me has no meaning unless it expresses a thought of God.”

- Srinivasa Ramanujan

The major focus of the department is to inculcate mathematical thinking in engineering students. For this we teach core mathematics courses to students at undergraduate level. Bridge courses are conducted for new engineering aspirants who take admission for the first year. Needy students are identified and special classes are conducted for them to perform well. As a result of the sincere effort of the team the department has been consistently obtaining good results.

The department faculty have published many papers in national and international journals. In addition the faculty members have also obtained extramural support to carry out research activities and applied projects sponsored by DST, SERB and NBHM.

The department has a dedicated staff strength of 7 members. Current expertise of the faculty covers a broad range of areas including Graph Theory, Fluid mechanics, Linear Algebra, Numerical Methods, Number Theory, Probability, Statistics and Queueing Theory.

Faculty List			
Sl.No.	Name	Designation	Experience
1	Mr. Sudhakar N (Ph.D)	Assistant Professor & Head	23 Years
2	Dr. Madhusudhan K V	Associate Professor	18 Years
3	Mrs. Priyanka N B (Ph.D)	Assistant Professor	16 Years
4	Mrs. Divya K (Ph.D)	Assistant Professor	16 Years
5	Mrs Bhanu Priya J (Ph.D)	Assistant Professor	5 Years
6	Mrs. Sarada Pratapa (Ph.D)	Assistant Professor	15 Years
7	Mr. Rangaswamy (Ph.D)	Assistant Professor	3 Years

Department of Physics

“Ask the right questions, and nature will open the door to her secrets”

- Sir C.V. Raman

Science is the basis for engineering and technology. The contributions and discoveries of science have led to the development of modern technologies. Scientific findings have been refined over decades and transformed into technology. Science is the cornerstone of technological progress.

Science's study of nature, or what we might call "nature" in general, is called physics. Natural events are understood by rigorous observation and reasoning. The Department of Physics at ATME College of Engineering was established in 2010 and features a modern building with a sophisticated learning atmosphere. The 120 square meter workspace of the department has a well-equipped laboratory, excellent modular experimental sets, and necessary IT infrastructure. The department's faculty members and other employees are highly engaged and dedicated.

The department's faculty members have an average of 14 years of teaching experience. The department works together to support students' academic well-being. The curriculum also depends on pupils' abilities being developed. The Department of Physics is integrating Outcome Based Education by fusing many contemporary concepts, including the flipped classroom, virtual classroom, blended classroom, and online classroom, in addition to the traditional classroom. The faculty has cleverly prepared and set up most of the experiments, which makes it easier for the students to understand the physical concepts. The department also instructs students in STEP software simulation experiments as part of the university curriculum.

The Department of Physics has a Research Center recognized by Visvesvaraya Technological University. The research center's operates in the areas of materials, tribology, and energy devices. Two research researchers are guided by Dr. Mahesh Lohith KS, Associate Professor and Head of the Research Centre.

List of Faculty of the Department				
Sl.No.	Name	Designation	Experience	Specialization
1	Dr. Mahesh Lohith KS	Associate Professor & Head	27 Years	Nuclear Physics, Materials, Tribology
2	Mr. Ramachandra M N (Ph.D)	Assistant Professor	21 Years	Nuclear Physics
3	Mrs. Rani T	Assistant Professor	14 Years	Solid State Physics
4	Dr. Madhusudhana R	Assistant Professor	17 Years	Nuclear Physics, Nanotechnology
5	Mr. Raghavendra R (Ph.D)	Assistant Professor	8 Years	Nuclear Physics
6	Mr. Anjan Kumar J	Assistant Professor	8 Years	Solid State Physics

List of Supporting Staff of the Department			
Sl.No.	Name	Designation	Experience
1	Mr. Sannappa D	Assistant Instructor	13 Years
2	Mr. Puneeth kumar Y M	Attender	17 Years

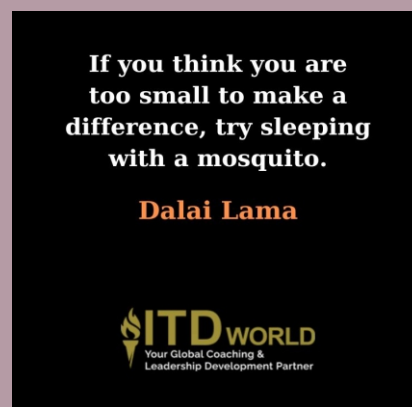

REPORT ON STUDENT COUNSELING SESSION ON MENTAL FITNESS FOR ACADEMIC TO OVERCOME PROCRASTINATION AND CAREER EXCELLENCE

Date of Session: 18th June 2025

Venue: C108

Time: 02:00 PM – 4:00 PM

Organized by: Department of Basic science

1. Introduction

A counselling session focused on overcoming procrastination was conducted on 18th June 2025. The session aimed to help students understand the causes of procrastination and provide them with effective strategies to manage their time and increase productivity.

2. Objectives

- To identify the psychological and behavioural roots of procrastination.
- To offer practical tools and techniques for better time management.
- To motivate students to develop consistent study habits.
- To encourage a growth mindset and self-discipline.



3. Resource Person

The session was facilitated by Ms. Sharanya, a certified counsellor and behavioural coach with experience working with adolescents and young adults.

4. Participants

Over 60 students from Engineering stream attended the session. The participants included students from various academic streams, all of whom had registered voluntarily for the program.

5. Session Highlights

- Introduction to Procrastination: Definition, signs, and common myths.
- Why Students Procrastinate: Fear of failure, perfectionism, lack of motivation, and distraction.
- Consequences: Academic stress, lower performance, guilt, and anxiety.
- Interactive Activities: Time management exercises, self-assessment questionnaires, and group discussions.
- Strategies to Overcome Procrastination:
 - o Breaking tasks into manageable parts
 - o Setting SMART goals
 - o Using the Pomodoro technique
 - o Developing self-discipline routines
 - o Reducing distractions (digital detox tips)
- Motivational Talk: Importance of building momentum and cultivating a success-oriented mindset.

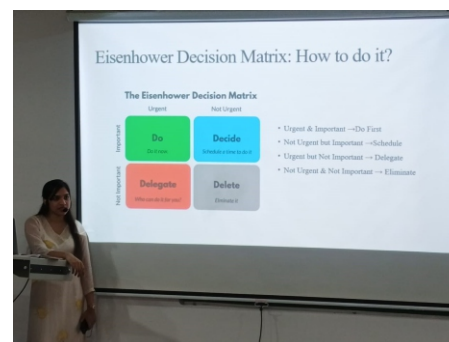

6. Conclusion

The session was a valuable initiative in addressing a common yet often overlooked issue among students. It equipped them with knowledge and tools to take control of their academic responsibilities more effectively. The Counselling Department plans to organize similar workshops periodically to reinforce positive behavioural changes.

DEPARTMENT OF CIVIL ENGINEERING

About the Department

The Department of civil engineering is growing tremendously over the years. With this small span of time the department has nurtured young minds to produce bright able civil engineers to the society. The department has expertise in almost the entire spectrum of civil engineering namely in Highway technology, Planning, Design, Construction and Management. The department with its multifaceted faculty continues to maintain and cultivate its strong links with infrastructural industry, academics and research. Many of our faculty members and students are involved in research activities in various areas of civil engineering. The department is developing strong links with the building and construction industry and academics. Along with the curricular the department encourages its students to take part in various cultural-sports-art festivals in and around the country.

The future civil engineers here are always taught with the practical applications by the field expertise. The department is also very active in conducting workshops, short term seminars etc. and at the threshold of planning of the technical festival.

Various lab facilities are provided to students here. The labs here provide expertise in Structural Engineering, Transportation Engineering, Geotechnical Engineering, Environmental Engineering, Hydraulics and Surveying. With these state of art infrastructure the students involves them in research with the guidance of expertise faculties.

HOD's Message

The department of civil engineering is emerging as one of the fastest growing branches by imparting quality education to the students in all the major areas of civil engineering. All the faculties in the department are well qualified with experience both from teaching and industry. The department is forecasting the vision of the college and striving hard for making students technically excellent, culturally vibrant, socially responsible and globally competent. The students are exposed to practical real time studies there by training them to analyse and provide solution for the same. Along with curricular, students are trained in all dimensions by means of seminar, workshops, Hands on work, technical talks, industrial visit, internships, site visit and many more. This provides a well built platform to enhance their enthusiasm and practical knowledge, which makes them to be confident to tackle any civil engineering challenges and be advanced and innovative with the growing technology.



Mr Manu Vijay

Report on “Interior Design Software with AI Applications”

Department of Civil Engineering organized a technical talk on “Sustainable Materials in Concrete” on 25thth November 2024 for 4th & 6th semester students with an objective of minimizing the gap between the academics and industry. Resource person during the presentation explained why the Interior Design Software with AI Applications

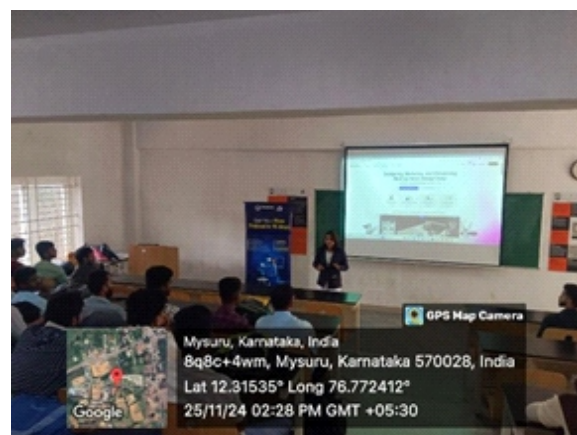

plays a vital role in civil engineering. The advanced methods of using the interior design software with AI applications is rapidly evolving, offering advanced tools that help designers create spaces efficiently and creatively. These AI-powered tools integrate machine learning, computer vision, and data analysis to enhance the design process, streamline workflows, and provide personalized recommendations.

ATAL FDP 2024

AICTE Teaching and Learning (ATAL) Academy Sponsored Six Day Faculty Development Program on “Innovative Approaches to Disaster Management and Resilience Infrastructure” from 9th to 13th December 2024 Organized by Department of Civil Engineering, ATME college of Engineering Mysore. The Inaugural Session of the Faculty Development Program was held on 9th December 2024 at 6:00pm in online mode through MS team platforms. Mrs. Shobha Arun, Head -CTEA, L & T limited Mysuru was the Chief Guest of the Inaugural function. Mr. Manu Vijay, Associate Professor & Head, Department of Civil Engineering, ATMECE welcomed the gathering. Dr. Basavaraj L, Principal, ATMECE Mysuru presided the event. Mrs. Shruthi H G, Assistant professor and Co-coordinator of the event brief up about the 6 day online FDP on “Innovative Approaches to Disaster Management and Resilience Infrastructure” funded by ATAL, AICTE. ”Dr. Suneeth Kumar S M, Professor, Department of Civil Engineering proposed the vote of thanks. Resource persons, Staff members of ATMECE and participants from various premier institutes, PG scholars and Industry persons witnessed the event.



Report on Drinking Water Project & RMC Plant

Department of Civil Engineering, ATMECE Mysuru in co-ordination with Association of Consulting Civil Engineers (ACCE), Mysuru Centre had organized one day technical site to Unduwadi Drinking Water Project, KRS Village, Mandya District and Infra RMC Pvt. Ltd, Hootgalli Industrial Area, Mysuru on 13th December 2024 for 3rd & 5th Semester Students.



Infra RMC Plant:

Ready Mix Concrete Manufacturing Plant is located in Hootagalli Industrial Area. At the time of visit Er. Pradeep explained in brief about the functioning of the plant. Later Students were taken to QA & QC laboratory facilities where quality of Construction Materials is assessed.



ATME College of Engineering Conducts Workshop for Engineers and Contractors in Association with ADANI Cement on 21-02-2025

ATME College of Engineering, in collaboration with ADANI Cement, recently organized a comprehensive workshop aimed at enhancing the skills and knowledge of engineers and contractors in the region. The event was presided over by Dr. L. Basavaraj, Principal of ATME College of Engineering, who highlighted the significance of industry-academia partnerships in fostering professional growth.

The workshop featured eminent resource persons Er. Hitesh Prasad Regional Technical Service Manager, Adani cements, Mysuru. And, Er. Harpreetsingh Jaggi South India Technical Head Adani cements, Mysuru who shared valuable insights on modern construction materials, sustainability, and best practices in the industry. Their sessions provided practical knowledge, bridging the gap between theoretical learning and on-site execution.



Report: "Industry Scope for Civil Engineers"

Date: 04/04/2025

Venue: Civil Department Seminar Hall

Organized by: Department of Civil Engineering

Speaker: Sri. Ashok Reddy Kollur, Technical Head South Karnataka, UltraTech cement

The Department of Civil Engineering successfully organized a technical talk on the topic "Industry Scope for Civil Engineers", aimed at enlightening students about the diverse career opportunities and the evolving landscape of the civil engineering industry.



The guest speaker, Sri Ashok Reddy Kollur a seasoned professional in the field with years of industry experience, delivered an insightful session that covered a wide array of sectors where civil engineers are in demand.

The talk also highlighted the growing importance of interdisciplinary skills, such as data analytics, software proficiency (like AutoCAD, STAAD.Pro, and Revit), and

knowledge of green construction technologies. The speaker emphasized how modern civil engineers are expected to blend traditional engineering skills with innovative solutions to meet global challenges such as climate change, rapid urbanization, and resource scarcity.





DEPARTMENT OF COMPUTER SCIENCE AND ENGINEERING

Department of Computer Science & Engineering

The Department of Computer Science & Engineering started in the year 2010. It is a evolving academic centre for higher education, research and novel in the key areas of Computer Science. It has been imparting quality education to meet the technological advancements and industrial requirements. The strength of students are progressively increasing every year and this is possible due to qualified and experienced faculties with excellent academic delivery process imparted. The first initiative taken by the department is “Computer Society of India - Student Branch”, which is a professional body at National Level, in the year 2012, all the students have got enrolled as a members to this branch. The department has obtained CSI institutional membership and maximum teaching faculties have become CSI life members and platform is provided for the students to enhance their technical skills by participating in various events conducted under this professional body.

Department has Centre of Excellence in networking -CISCO, by providing CCNA Certification to students in networking and all final and pre final year semester students have done internship under this programme.The Department signed MOU with ATEU Softwares,

Mysore to conduct various technical training for the students. The Department got sanctioned One Lakh Rupees from SERB for the three Day National Seminar conduction.

The Department of Computer Science & Engineering started in the year 2010. It is a evolving academic centre for higher education, research and novel in the key areas of Computer Science. It has been imparting quality education to meet the technological advancements and industrial requirements. The strength of students are progressively increasing every year and this is possible due to qualified and experienced faculties with excellent academic delivery process imparted. The first initiative taken by the department is “Computer Society of India - Student Branch”, which is a professional body at National Level, in the year 2012, all the students have got enrolled as a members to this branch. The department has obtained CSI institutional membership and maximum teaching faculties have become CSI life members and platform is provided for the students to enhance their technical skills by participating in various events conducted under this professional body.

Department has Centre of Excellence in networking -CISCO, by providing CCNA Certification to students in networking and all final and pre final year semester students have done internship under this programme. The Department signed MOU with ATEU Softwares,

Mysore to conduct various technical training for the students. The Department got sanctioned One Lakh Rupees from SERB for the three Day National Seminar conduction. The Department has got library, which believes in sharing of knowledge in the form of books, the most novel way of building the young mind by technical and ethical knowledge for students. Department also conducts various workshops, technical talks, and CSI events to students to up skill their skills.

Department Activities

Introduction to Block chain

The Department of Computer Science and Engineering has organized a technical talk for 5th and 3rd semester students on 8th Nov 2024 at Seminar Hall. The technical talk focused on giving an insight into



Blockchain technology, importance and benefits of blockchain. The talk also focused on discussing the carrier opportunities and future of blockchain opportunities. The speaker for this technical talk is Mr. Sreenivas Aprameya, Founder of Accelchain.



Cyber Hygiene Practices to achieve cyber safety

The Department of Computer Science and Engineering has organized a technical talk for 5th and 3rd semester students on 25th Nov 2024 . The technical talk focused on giving an insight into Cyber Hygiene Practice. The resource person for the workshop was Mr Vipul Kumar, Project Associate, CDAC Bangalore.

Cyber hygiene practices are a set of actions that can help keep your devices, networks, data, and users safe from cyber threats. The practices and procedures that individuals and organizations use to maintain the health and security resilience of their systems, devices, networks, and data.



Artificial Intelligence, Machine Learning and Deep Learning in the Data Revolution Era: Progress and Applications

The three-day workshop Faculty development program was organized on “Artificial Intelligence, Machine Learning and Deep Learning in the Data Revolution Era: Progress and Applications” from 3rd Feb,2025 to 5th Feb, 2025. The event commenced on 3rd February 2025 with a grand inaugural ceremony graced by our Chief Guest, Dr. Thotreingam Kasar, an esteemed expert in the field of AR/ VR and AI. We were also honored by the presence of our beloved Principal, Dr. L. Basavaraj, and our Advisory Committee Members Dr. Bhagashree SR, Dean Research and Dr. Srinivasa K, Dean Student Affairs, Convenors Dr. Puttegowda D and Dr. Anil Kumar C J, whose continuous encouragement and guidance made this FDP a grand success. The 3-Day Faculty Development Program (FDP) witnessed active participation, with 50 attendees from both academic institutions and industry.

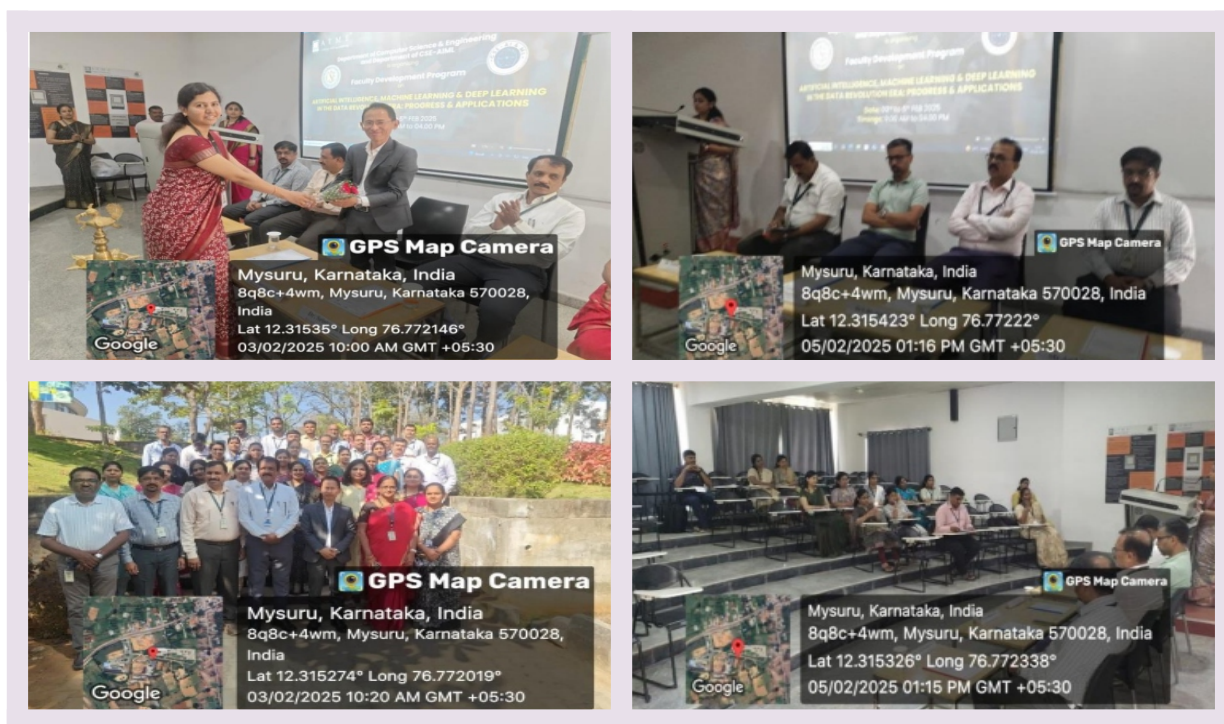

ALUMNIMEET

Alumni Meet was organized on 22nd, Feb 2025. Alumni's were invited for the event. Juniors gave warm welcome to their seniors (Alumni). During this meet, the alumni community shared their experience, struggle what they faced after stepping out of the institution with their juniors, faculties and HOD. After interaction section, lunch was arranged for all the alumnis.



AYUDHA POOJA

Ayudha pooja or Maha Navami, on the 9th day of Navratri, is one of the most significant aspects of the nine days which is celebrated by worshipping tool and equipment. On 10th October, 2024 Ayudha pooje festival is celebrated, where all teaching and nonteaching staffs including HOD were present. On this occasion, computers, books and other equipment was worshipped.



Department CLUB- Logo Launch

The Department of Computer Science and Engineering at ATME College of Engineering proudly inaugurated its official student club, UDGHAM, under the theme “Raising Bytes of Wisdom”. Held on 16th April 2025, the logo launch event marked the beginning of a student-driven platform for technical, creative, and collaborative growth. The UDGHAM Logo Launch Event was a proud and promising moment for the Department of Computer Science and Engineering. With support from faculty and the

energy of enthusiastic students, the club is now geared up to host various workshops, talks, competitions, and learning events that align with its mission of Raising Bytes of Wisdom.



Industrial Visit

The Department of Computer Science and Engineering organized an enriching Industrial Visit to System Consultant Information India (P) Ltd, a Japanese-based IT company located in Tumkur, on 24th April 2025. This visit aimed to bridge the gap between theoretical knowledge and real-world industry practices. A total of 50 members, including two faculty members – Mrs. Keerthana M M and Dr. Shilpa B L, took part in the visit. Members of the UDGHAM Club volunteered and supported the successful coordination of the event. The industrial visit was a grand success, both educational and enjoyable. Students gained valuable exposure to the corporate environment, enhanced their technical understanding, and created memories filled with learning and fun. UDGHAM Club members played a vital role in organizing and managing the visit, ensuring its smooth execution.



Unlock the unknown

The Department of Computer Science and Engineering, under the innovative club UDGHAM - Raising Bytes of Wisdom, has organized the event "UNLOCK THE UNKNOWN " on 8th May 2025 . The event focused on skills-oriented aptitude, mind analysis and brain tricking. Students of 4th and 6th semester

actively participated. Dept HOD, Dr. Puttegowda D and Club Mentor Mrs.Keerthana M M, sincerely appreciated the student coordinators and volunteers for their remarkable efforts in planning and executing the event with dedication, enthusiasm, and professionalism. Their proactive involvement, creativity, and teamwork played a pivotal role in ensuring the success of the program.



CSE Research Center

Mr. NAITHIK KUMAR S T, bearing USN 4AD18PCS03 has successfully completed PhD in CSE research Center, ATME college of Engineering on 25-06-2025 under the guidance of Dr.J.V.Gorbal and external examiner was Dr.Vamshi from NITK, Surathkal. His research topics was “ Enhancing User Authentication Process By Multimodal Biometric System Using Deep Learning Techniques”. We from department of CSE Congratulate Dr.Naithik Kumar.



Dr. Puttegowda D

BOS, Mysore University School of Engineering, University of Mysore
BOE, VTU, Belagavi

Students Achievements

Congratulations!!

Mr. Shivashankar B Naik 6th semester and Ananth Kumar V 8th semester students, to represent VTU softball Men in All India Inter University Championship held at Vikaram simhapuri University Nellore(AP) from 3rd to 7th May-2025.



Congratulations!!

Mr. Bhuvan S and Adithya K.L., 8th semester students, to represent VTU Baseball Men Team in All India Inter University Softball Championship held at Punjab University, Chandigarh from 12th to 16th May-2025.

Congratulations!!



Ms. Harshith, 8th semester student for getting 3rd prize in 5K Marathon. Marathon was organized as a part of ATMEYA 2K25 "Ability Beyond Disability" on 17th May, 2025. Chief Guest was Prof. C. Ventakesh, Director, Physical Education, University of Mysuru and Ms. Chaitra B, International Kho-Kho player.

Congratulations!!

Mr. Shivashankar B Naik and Mr. Rahul R 5th semester students, Participated in Men MCICT Inter-Collegiate Softball Championship 2024-2025 organized by SBRR Mahajana FGC, Mysure on 25-26, November 2024 and Emerged as a champions .



Congratulations!!

Ms. Pooja Hebbar, 7th sem student, Participated in women MCICT Inter-Collegiate Softball Championship 2024-2025 organized by SBRR Mahajana FGC, Mysure on 25-26, November 2024 and Emerged as a champions .





DEPARTMENT OF COMPUTER SCIENCE & DESIGN / CYBER SECURITY

Department of Computer Science & Design/Cyber Security

The Department of Computer Science & Design (CSD), established in 2021 with an intake of 60 students, is a pioneering center for higher education, research, and innovation at the intersection of technology and design. Our Bachelor's program uniquely integrates computing, creativity, and design, preparing students for diverse careers in IT, gaming, animation, virtual and augmented reality, robotics, and digital analytics. The curriculum covers software development, website construction, image processing, animation, graphics, game development, and fundamentals of video and photography, laying a strong foundation for both immediate industry roles and advanced studies.

The department is guided by highly qualified faculty with a balanced mix of academic and industry experience, ensuring students gain the right blend of theory and practical expertise. Equipped with state-of-the-art laboratories and excellent infrastructure, the department also actively motivates its students to participate in various technical, cultural, and co-curricular activities, fostering all-round growth and innovation through a focus on Human-Computer Interaction design processes.

Student Achievement for AY 2024-25

Student Startup-SKULLERR

Students from the Department of Computer Science and Design have launched a startup named “SKULLERR”, founded by Rohan Prasanna Shenoy, a 7th-semester student, along with his fellow classmates. SKULLERR: Empowering Tech Careers

SKULLERR is a student-led startup providing in-person training and career development for aspiring tech professionals. By offering hands-on workshops, industry-relevant courses, and expert mentorship, SKULLERR equips individuals with the skills needed to excel in the fast paced tech industry.

Specializing in areas like software development and Cyber Security, the platform ensures students stay ahead with an evolving curriculum and career-focused support, including job placement assistance and networking opportunities.

SKULLERR is dedicated to turning tech aspirations into achievements, helping individuals launch and advance their careers. The startup is also MSME registered with a registration No. UDYAM-KR-22-0047609.

The image shows two promotional materials for SKULLERR. On the left is a business card with a geometric orange and blue pattern. It includes contact information: phone number +91 734 892 7721, location Dattagalli, Mysuru, email skullerrindia@gmail.com, and Instagram handle @skullerr. The slogan reads "THERE IS NO ELEVATOR TO SUCCESS, YOU HAVE TO TAKE THE STAIRS" and features the MSME logo. On the right is a flyer titled "WE ARE A START-UP COMPANY WHICH HELP THE STUDENTS TO BUILD THEIR SKILLS BY ATTENDING OUR WORKSHOPS." It is divided into three sections: "ABOUT US" (describing 2-day workshops on AI, Cyber security, etc.), "COURSES" (listing AI, Web Development, Ethical Hacking, IoT, etc.), and "TEAM SUNSHINE" (introducing founders Rohan Prasanna Shenoy, Mohammed Ameen, and Shishira N Raj).

Ms. Madhurya H V a 2nd year student was awarded as the Best Presenter in National Level Paper Presentation Held at Bangalore Technological Institute, Bangalore on 25 April 2025. She presented a paper titled “Quantum Satellites-The Future of Unhackable Communication”.

A vertical certificate from Bangalore Technological Institute (BTI). The text reads: "This is to certify that MADHURYA H V 2ND YEAR CS AND DESIGN ENGINEERING ATME COLLEGE OF ENGINEERING MYSURU - KARNATAKA - INDIA HAS PARTICIPATED IN THE 'TECHNOLOGY'25 - A NATIONAL LEVEL STUDENT PAPER PRESENTATION COMPETITION (OFFLINE MODE), ORGANISED BY BTI INCUBATION CENTRE - BANGALORE TECHNOLOGICAL INSTITUTE IN ASSOCIATION WITH BTI STUDENT'S CLUB ON 25.4.2025 (FRIDAY) AT BTI SEMINAR HALL. TOPIC : QUANTUM SATELLITES (THE FUTURE OF UNHACKABLE COMMUNICATION)". The certificate is signed by Pruthvi Narayana Reddy (General Secretary), Dr. Prabhakar Sekar (Director), and Dr. H S Nanda (Principal). It includes logos for BTI, AICTE, ISO, and NAAC, and a QR code. The certificate number is 009.

Ms. Chandana Chinmayee Umesh and Mr. Chiranth S 2nd year student from Department of CSE-Cyber Security, secured First Place in various technical events such as Tech Trail, Patch Frenzy, Brain Teaser conducted as part of TechnoVVISTA 2.0 at Vidya Vikas College of Engineering, Mysuru held on 19th May 2025.



Two days workshops on Artificial Intelligence, Power BI, and AR/VR

The Department of Computer Science and Design (CSD), in collaboration with the student-founded startup SKULERR, India, and the Institution's Innovation Council (IIC), organized a two-day workshop focusing on cutting -edge technologies in the fields of Artificial Intelligence (AI), Power BI, and Augmented Reality/Virtual Reality (AR/VR). The event took place on 24th and 25th July 2024 at the college premises and was designed specifically for students from the Computer Science and Engineering (CSE) and allied branches. The objective of the workshop was to provide students with practical exposure to these rapidly evolving domains and empower them with industry-relevant skills.

The workshop was a hands-on training session conducted by renowned professionals from Microsoft and TechShiksha, providing students with a blend of theoretical knowledge and practical experience in the areas of AI, Power BI, and AR/VR. The sessions were interactive and involved real-world case studies, providing students an opportunity to gain insights into the latest advancements in technology.



Trainers of the Event:

1. Mr. Shridharan V, Associate Vice President, Global Logic, A Hitachi Company
2. Mrs. Poornima S, Microsoft Valued Professional, NextGen Coach, AI Instructor, TechShiksha
3. Mr. Vinoth E, AI and AR/VR Instructor, TechShiksha



Technical Talk on Charting Future Opportunities in AR, VR & AI

The Department of Computer Science and Design at ATMECE hosted a technical talk titled "Charting Future Opportunities in AR, VR & AI" October 28, 2024, in the college seminar hall. Dr. Thotringam Kasar, Director of the Edspire Research Centre in Mysuru, was the speaker, sharing insights into the emerging opportunities within the fields of AR, VR, and AI.



Industrial Visit to Cyber Security Centre of Excellence at MYRA School of Business, Mysuru on November 9, 2024

The department of Computer Science & Design together with Department of Computer Science & Engineering- Cyber Security organized a visit to the “Cyber Security Centre of Excellence” Lab at MYRA School of Business, Mysuru on November 9, 2024, for 3rd semester students.

The CoE is outfitted with cutting-edge labs, tools, and technologies designed to train both students and professionals to effectively address modern Cyber Security challenges. It acts as a hub for both theoretical learning and practical experience in the dynamic field of Cyber Security. This visit provided an opportunity to explore how Cyber Security principles are applied in real-world scenarios,

engage with industry experts, and learn about the latest technologies shaping the Cyber Security landscape.



Industrial Visit to Microsoft Office, Luxor, Bangalore

The department of Computer Science & Design in association with Institute Innovation Council, organized a visit to the “Microsoft Office, Luxor Tower at Bangalore” on November 23, 2024, for students of CSE & Allied branches. The visit provided students with invaluable industry exposure and networking opportunities. Led by SKULERR India members, participants attended insightful sessions by Microsoft experts:

- Mr. Sagnik Banerjee discussed technology's future and Microsoft's innovations.
- Ms. Shreya Suman highlighted Generative AI tools like Copilot.
- Mr. Nirmal Krishna guided students on joining the Azure Community.



Interactive activities and networking enhanced the experience, with winners receiving exclusive goodies. The event boosted students' technical skills, professional connections, and enthusiasm for innovation, embodying SKULERR India's vision of blending academic learning with industry exposure.



Report on: Industrial Visit to Microsoft Office, Bengaluru on February 22, 2025

SKULERR TECH EXPEDITION Phase III

The Department of Computer Science and Design in association with Skulerr organized a second Industrial Visit to **Microsoft Office**, Bengaluru on February 22, 2025. Building upon the immense success of the **SKULERR TECH EXPEDITION Phase II**, the third phase brought an exceptional opportunity for the participants to connect directly with the tech industry at its finest. Held at the **Microsoft Office, Luxor**, this phase offered an immersive and enriching experience, fulfilling the primary goal of strengthening students' professional networks and equipping them with skills in cutting-edge technologies.

Highlights of the Visit

The day commenced with enlightening sessions delivered by prominent Microsoft professionals, including:

- **Mr. Sagnik Banerjee**, who provided insights into the future of technology and Microsoft's role in driving innovation.
- **Ms. Shreya Suman**, who emphasized the potential of **Generative AI tools**, focusing particularly on **Copilot** and its applications in various domains.
- **Mr. Nirmal Krishna**, who shared valuable guidance on becoming part of the **Microsoft Azure Community**, opening doors to numerous learning resources and collaboration opportunities.

Accompanied by **Dr. Pavithra A C**, Associate Professor and six Skuller members, students gained insights into cutting-edge technologies, Generative AI, Microsoft Copilot and Microsoft Azure Community through expert-led sessions. The day was packed with interactive activities, fostering creativity and teamwork.



Students Clubs

Department of Computer Science and Design

CRESIGNS – Idea Club **Creating Ideas to Ignite Innovation**

CRESIGNS is the official student-run club of the Computer Science and Design (CSD) Department, founded with the vision of blending creativity with technology. The name “CRESIGNS” is derived from Creative Designs, symbolizing the club's mission to nurture innovation at the intersection of art, design, and computing.

The club was launched by Head of the Department Dr. Naseen Fathima on 26th March 2025. At its core, CRESIGNS is a platform for students to explore and express their talents in areas such as UI/UX design, digital illustration, creative coding, animation, game design, and human-computer interaction. It encourages hands-on learning and collaborative projects that bring design thinking into the realm of computer science.

CRESIGNS also serves as a creative community—one where ideas are exchanged freely, feedback is constructive, and collaboration is key. Whether it's prototyping a new app interface or creating motion graphics for a social cause, the club fosters a culture where imagination meets implementation.

Open to all CSD students with a passion for creativity, CRESIGNS continues to inspire a new generation of tech-driven designers ready to shape the digital future.

CRESIGNS Club Members

1. President: M Yeshashwini Madhumitha
2. Secretary: T Varsha Nanjappa
3. Registration Head: T Varshitha Nanjappa
4. Documentation Head: Tasbiya Taskin
5. Logistics & Operation Head: Spoorthi C N
6. Faculty Mentor: Prof. Yogesh N



VTU RANK HOLDER

2024-25 CS&D



Vishwas B
4AD21CG035

VTU- 9th Rank (CGPA- 9.31)

**COMPUTER SCIENCE AND
DESIGN**

Mr. Vishwas B, a student from the 2021-25 batch of Computer Science and Design department, secured 9th rank as the branch topper at the 25th Annual Convocation of Visvesvaraya Technological University held on 4th July 2025.

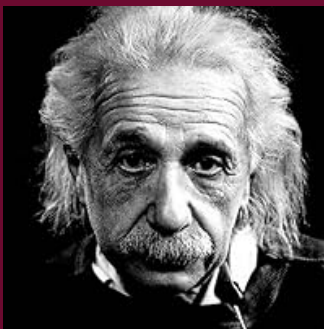

Two things are infinite: the universe and human stupidity; and I'm not sure about the universe.

- Albert Einstein

ODD SEMESTER TOPPER LIST- Department of CSD**3rd SEM TOPPER LIST****2024-25**

USN	STUDENT NAME	SGPA 3rd SEM	CGPA as on 3rd SEM
4AD23CG016	MAHADEVAPRASAD YESHASHWINI MADHUMITHA	9.33	9.25
4AD23CG040	T VARSHA NANJAPPA	9.14	8.82
4AD23CG003	AKSHATHA M	8.95	8.89
4AD23CG041	T VARSHITHA NANJAPPA	8.95	8.80

5th SEM TOPPER LIST

USN	STUDENT NAME	SGPA 5th SEM	CGPA as on 5th SEM
4AD22CG044	UMME KULSUM	9.18	9.17
4AD22CG038	RAHUL PRAKASH H P	9.18	9.30
4AD22CG029	MONALISHA U	9.00	8.96

7th SEM TOPPER LIST

USN	STUDENT NAME	SGPA 7th SEM	CGPA as on 7th SEM
4AD21CG004	C SMRITI EMMANUEL	9.67	8.69
4AD21CG031	SNEHA K	9.54	8.11
4AD21CG025	ROHAN PRASANNA SHENOY	9.42	8.58



DEPARTMENT OF DATA SCIENCE

About the Department

The Department of CSE(Data Science) is supported by a team of highly qualified, passionate faculty who stay abreast of the latest industry trends. Our students are motivated and equipped with hands-on experience in cutting-edge technologies and programming languages, preparing them for successful careers in the IT sector. With a strong foundation in data science— leveraging mathematical and statistical models, machine learning tools, and artificial intelligence—they are well-prepared to derive insights and recommendations that address realworld challenges. The department is equipped with modern tools and technologies, and the institute provides placement training in aptitude, technical skills, and soft skills to enhance employability.

At ATMECE, we emphasize enriching the learning experience by offering value-added courses, skill-enhancement programs, and opportunities to participate in technical symposiums and hackathons organized by leading institutes nationwide. Our mission is to transform students holistically, enabling them to face societal challenges and contribute as responsible citizens to a better India and a better world. To prepare our students for Industry-ready, the Department has MoU with IVIS labs, which provide Domain Specific Training around Data Engineer, Applied Machine Learning and Generative AI. This enables the students to exhibit their Technical skills in the field of Data Engineering.

Milestone of the Department

Recognized as one of the Higher Education Review Top 10 promising Colleges for Data Science in India – 2024.

Department Activity

The Department of Computer Science & Engineering (Data Science) at ATME College of Engineering successfully organized a Three-Day State-Level Faculty Development Program (FDP) on "Unlocking Generative AI" from February 10th to 12th, 2025. The program aimed to provide a foundation in Natural Language Processing (NLP), Prompt Engineering, and Hands-on Training aligned with the VTU syllabus for the 6th Semester subject "Generative AI – BAIL657C". The event was held in association with IEL, ATME IEEE Student branch 35744, IQAC- ATMECE.

The FDP was inaugurated by Dr. L. Basavaraj, Principal, ATMECE, in the presence of distinguished guests, faculty members, and participants from various institutions. The welcome speech was delivered by Dr. Anitha D B, Associate Professor & Head, CSE-Data Science, highlighting the growing importance of Generative AI in academia and industry. She emphasized how NLP and AI-driven models like GPT, BERT, and LangChain are revolutionizing modern technology.



INAUGURATION OF 3 DAYS STATE LEVE FDP

The FDP featured expert talks and practical demonstrations by Dr. Meenakshi H. N. (Senior Principal Consultant, Infosys, Mysuru) and Mr. Siddhanna Janai (Analyst in Learning, Infosys, Mysuru). The Vote of Thanks was delivered by Dr. Vinod Kumar P, Associate Professor, CSE-Data Science, expressing gratitude to the management, resource persons, ATME IEEE Student volunteers, faculty coordinators, and participants for their support and active involvement.

MOU-Memorandum of Understanding with IVIS Lab

IVIS lab provides Domain specific training for our students on Data Engineering, Applied Machine Learning and Generative AI (Prompt Engineering) domains.



Inaugural of Technical Club

The Department of CSE (Data Science) successfully launched its technical club DataNauts on 14th May 2025 at AB401 in the esteemed presence of Dr. Basavaraj L (Principal), Dr. Anitha D B (Associate Professor & HoD), and Mr. Yogabalaji G, Decision Scientist at Mu Sigma Inc., Bengaluru, along with faculty members and students of the department.



The inaugural event concluded with a technical talk by Mr. Yogabalaji on “How Data is used to Build Solutions and Maximizing Efficiency”, offering valuable industry insights to the 4th and 6th semester students.

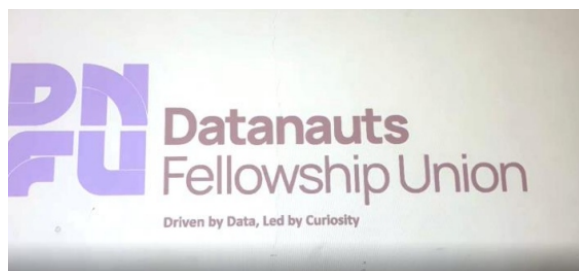

Outreach Event :

The Department of Computer Science and Engineering (Data Science) organized a outreach activity at Hallikerehundi village on 10th May 2025, from 2:00 PM to 4:00 PM. The event was conducted by the 6th semester students with the objective of meaningfully engaging with the local community and spreading awareness on relevant social, health, and digital topics.

As part of the outreach, the students performed an engaging skit to raise awareness about breast cancer, emphasizing early detection, regular check-ups, and the importance of not neglecting one's health. The performance was well-received and effectively conveyed the message to the audience.

Following the skit, students delivered informative talks covering various key topics:

- Environmental protection and the need to avoid the usage of plastic
- The importance of healthy and nutritious food habits
- Digital literacy and safety in the age of increasing internet use

The member of Grama Panchayat Mr. Srinivasa appreciated the students' efforts and addressed the gathering by reinforcing the messages shared. He urged the villagers not to ignore health symptoms and to seek timely medical assistance. He also advised the community to adopt the sustainable and health-conscious practices highlighted by the students.

Glimpse of the Activity





STUDENT ACTIVITY

Technical Talk

Sl No.	Date	Name of the Activity	Participants Semester	No of Participants
1	18/9/2024 to 20/9/2024	Student Enablement Program on Python Programming Infosys Spring board	3 rd Sem	59
2	20/11/2024	Technical Talk on “Data Science & its Application” Resource Person : Mr. Vignesh 5 th Sem Student	3 rd Sem	59
3	16/10/2024	Technical Talk on “Data-Driven Innovation: Exploring the World of Data Science” Resource person: Sunil Gowda T H	7 th & 5 th Sem	120
4	9/10/2024	Technical Talk on “ Empowering Sustainability Aligning with AICTE Activity Points Resource Person : Ms. Seemanthini C Consumers for Sustainability - NGO	3 rd & 5 th Sem	122

FACULTY ACTIVITIES

Faculty Achievements			
Sl. No.	Date	Activities	Name of the faculty
1	Dec-2024	Session Chair for ICDWCI_2024 at CIT, Mandya	Dr. Anitha D B
	Nov-2024	Member Board of Studies in Artificial Intelligence and Data Science for a period of 3 years (2024 to 2027) University of Mysore	Dr. Anitha D B
2	Nov-2024	Resource Person for Hand on workshop at Jain (Deemed to -be University), Bengaluru	Dr. Anitha D B
3	Nov-2024	Resource person for Innovation in PCB manufacturing and end to end overview at JSSSTU, Mysuru	Dr. Anitha D B
4	Dec-2024	Session Chair at CMRIT	Dr. Vinod Kumar P
5	Aug-2024	Resource person for applications of Python at JSSW Polytechnic, Mysuru	Dr. Neethi M V
6	Sep24	Ph.D Awarded by VTU	Dr. Neethi M V
7	Aug-2024	Session Chair at Myscon conference 2024	Dr. Anitha D B & Dr. Vinod Kumar P

FDP Attended

SL. No.	Name of the Faculty	Title	Date	Organized by
1.	Ms Ambika V	Artificial Intelligence in Block chain	26.08.2024 to 31.08.2024	DMI Engineering College, Aralvaimozhi, Kanyakumari District
2	Dr. Neethi M V	Data Analytics and Visualization with Power BI and Tableau	9-09-2024 To 13-09-2024	CMR Institute of Technology Bengaluru

MOOC Certifications (NPTEL)

SL No.	Faculty Member	Course Title	Platform	Duration
1	Dr. Anitha D B	<ul style="list-style-type: none"> ○ Python for Data Science ○ The Joy of Computing using Python 	NPTEL	4 Weeks 12 weeks
2	Dr. Vinod Kumar P	<ul style="list-style-type: none"> ○ Advanced R Programming for Data Analytics in Business ○ Cloud Computing ○ Cyber Security ○ Artificial Intelligence using Prolog Language 	NPTEL	12 weeks
3	Dr. Neethi M V	<ul style="list-style-type: none"> ○ Programming in Python 	NPTEL	4 weeks 12 weeks
4	Mrs. Madhu Nagaraj	<ul style="list-style-type: none"> ○ Programming in Python 	NPTEL	4 weeks 12 weeks
5	Ms. Ambika V	<ul style="list-style-type: none"> ○ Cryptography 	NPTEL	12 Weeks



Sharadhi of Data Science Student participation at Table tennis and securing second place , held at VVCE, Mysuru



Ms. Prakruthi of Data Science secured prize during softball competition organized at UoM, Mysuru

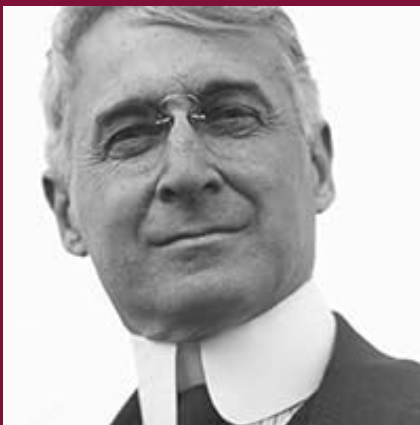

Be who you are and say what you feel, because those who mind don't matter, and those who matter don't mind."

- Bernard M. Baruch

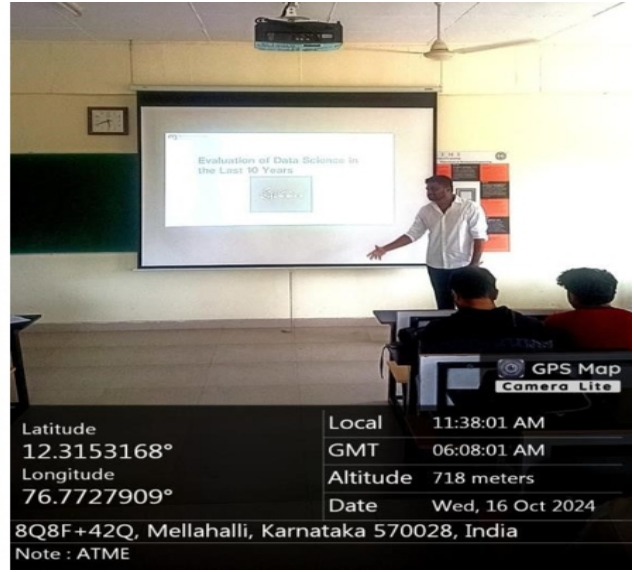

Data-Driven Innovation: Exploring the World of Data Science

Students' participation in technical activities

Sl. No	Date	Activities	Name of the Student
1	13 th to 14 th December 2024	Hackelite24 SJCE (24 hour Hackathon on social or business things)	Vignesh T D
2	24 th and 25 th October 2024	Annual International Conference on Recent Trends in Healthcare Innovation (AICRTHI) 2024	Alaina Rahim
3	24 th and 25 th October 2024	Annual International Conference on Recent Trends in Healthcare Innovation (AICRTHI) 2024	Aishwarya S
4	20-12-2024	Project Expo-2024 at GSSS IETE student's branch	Chaitra M G, Kavana S G, Nagashree B S, Syed Mouzam Fakrulla
5	20-12-2024	Project Expo-2024 at GSSS IETE student's branch	Kavya D M, Prashanth, Drishyaa A S, Mohan Kumar N D
6	20-12-2024	Project Expo-2024 at GSSS IETE student's branch	Pragathi M, Raksha H G
7	20-12-2024	Project Expo-2024 at GSSS IETE student's branch	Sinchana M J, Usha D Kruthika R, Maanya P
8	22-11-2024	IEEE -'Student Leadership Summit and IES day Celebration'	Srushti, Thrupthi
9	23-11-2024	SKULLER TECH EXPEDITION Phase II at Microsoft Luxor, Bangalore	Srushti, Thrupthi Maheshvari,
10	23-11-2024	SKULLER TECH EXPEDITION Phase II at Microsoft Luxor, Bangalore	Heeba Arshi
11	28-06-2024	IEEE SWEAT 2024 Symposium –cum workshop on Emerging AI ML Trends at Bengaluru	Dyan Siddarth R, Chethan S, Jayanth D

ACADEMIC YEAR 2024-25 TOPPERS LIST

3rd Semester



MANASA M
4AD23CD024 9.67



PRAMODINI N
4AD23CD036 9.19



ILHAN MANSIJ JIDDA
4AD23CD016 9.19

5th Semester



NIKITHA B
4AD22CD030 9.55



NEHA MERIN DSOUZA
4AD23CD029 9.14

7th Semester



KAVYA D M
4AD21CD022 9.54



AYAAN SHAREEF
4AD21CD005 9.54



M G CHAITRA
4AD21CD025 9.29





DEPARTMENT OF ELECTRONICS & COMMUNICATION

About the Department

The Department of Electronics and Communication Engineering (ECE) at ATME College of Engineering was established in 2010 with an initial intake of 60 students, which was increased to 120 in 2012. The Department is supported by qualified and experienced faculty, well-equipped laboratories, and a strong emphasis on research through its EC Innovative Research Club (EC-IRC). The Department focuses on key research domains such as Wireless Communication, Image Processing, Computer Networks, Control Systems, VLSI Design, and Embedded Systems.

It actively promotes industry-academia collaboration and enhances student exposure through workshops, seminars, industrial visits, and internships aimed at bridging the gap between academic learning and practical implementation.

Faculty Achievements

- Dr. Prathibha MK appointed as Board of Examiner, Department of ECE, VTU Belagavi for AY 2024–25.

- Dr. Bhagyashree S R received the International Outstanding Academy Award in the field of Biomedical Embedded Systems at IISTAR Congress 2024, presented by the Hon'ble Education Minister of Tamil Nadu (20/10/2024).
- Ms. Anupama Shetter received a research incentive of 10,000 for authoring and publishing a book.

Workshops & Faculty Development Programs

1. ATAL Advanced FDP on “Next-Gen System—On-Chip Design for Advanced Semiconductor Solutions,” RV College of Engineering, Bengaluru (12–24 July 2024) – Attended by Mrs. Swetha K T and Ms. Mythri R.
2. Workshop on AICTE Activity Points, Shree Krishna Institute of Technology (23 Nov 2024) – Attended by Mr. Chandra Shekar P.
3. STTP on “Application of Deep Learning in Multidisciplinary Area,” NITK Surathkal (1–5 July 2024) – Attended by Dr. Shalini Hanok.
4. FDP on VTU Internship Program, Rooman Technologies & VTU Mysuru (13–14 Sept 2024) – Attended by Mr. Chandra Shekar P.
5. Workshop on “EM to RF Evolution: State of the Art 6G Systems,” MSRIT, Bengaluru (24–28 June 2024) – Attended by Mrs. Keerthi A Kumbar.
6. Export Management System Training, in association with GOK Mysuru (24–29 June 2024) – Attended by Mr. Girish M.
7. Hands-on Workshop on Medical Imaging, IEEE-EMBS & GAT, Bengaluru (22 June 2024) – Attended by Ms. Anupama Shetter and Mrs. Juslin F.
8. FDP on “Cyber Security Awareness and Emerging Technologies for Secure Social Media & Banking Applications” from 10/03/2025 to 12/03/2025 at ATMECE, Mysuru attended by All the staff of Electronics and communication
9. Mr. Chandra Shekar P and Ms. Anupama Shetter has attended One week FDP titled “ The Art of Writing Orginal Research Article” organized by ProMind Research Academy, Erode from 2/6/2025 to 6/6/2025.
10. Ms. Anupama Shetter has attended two weeks FDP titled “Advance Tools and Techniques for Research Methodology” organized by Research Foundation of India from 02/06/2025 to 12/06/2025
11. Workshop on Patent Drafting, Filing & Interpretation from 12/06/2025 to 14/06/2025 at ATMECE, Mysore attended by all the staffs of ECE Department.

12. Mr.Chandra Shekar P has successfully completed Intellectual Property Rights on Udmy Platform on 18/06/2025

NPTEL SWAYAM Courses Completed

- Dr.PRATHIBHA M K “Managing change in organizations”(Jan-Mar 2025;8 weeks) – Elite Badge
- Dr. PRATHIBHA M K “Accreditation and Outcome Based Learning (Aug-Oct 2024; 8 weeks,) – Elite Badge
- **Dr. Veerapraphap V** – “Psychology of Everyday” (Aug–Sept 2024)
- **Mrs. Swetha K T** – “An Introduction to Coding Theory” (8 weeks, July–Sept 2024), “Basic Course on Electric and Magnetic Circuits” (12 weeks, July–Oct 2024) and “NBA Accreditation and Teaching and Learning in Engineering (NATE)”(12 weeks, Feb 2025) – Elite Badge
- **Ms. Mythri R** – “The Joy of Computing Using Python” (12 weeks, July–Oct 2024)
- **Mr. Chandra Shekar P** – “AI/ML for Geodata Analysis,” conducted by ISRO & Indian Institute of Remote Sensing (19–23 Aug 2024)
- **Dr. Shalini Hanok**-“NBA Accreditation and Teaching and Learning in Engineering (NATE)”(12 weeks, Feb 2025) – Elite Badge
- **Mrs. Keerthi Kumbar**-“Ethics in Engineering Practice”(8 weeks, FEB-April 2025)- Elite Badge
- **Mr. Pradeep kumar Y**-“ Academic Leadership in Cross Cultural Context of Higher”(8 weeks FEB-April 2025)- Elite Badge

Resource Person Contributions

- **Dr. Bhagyashree S R**
 - FDP on “Value-Based Leadership in Education,” Navkis College of Engineering, Hassan (20–22 Dec 2024)
 - FDP on “Enhancing Teaching and Learning Process Using ICT Tools,” PES Mandya (5–8 Nov 2024)
- **Mr. Manjunath K** – Workshop on LaTeX, organized by Department of Data Science, ATMECE (7–9 April 2025)

Conference Reviewer Roles (IEEE)

- IEEE MysuruCon 2024 (30–31 Aug 2024): Ms. Anupama Shetter, Mrs. Juslin F, Mrs. Keerthi A Kumbhar, Mr. Girish M, Mr. Manjunath K, Mr. Chandra Shekar P
- IEEE ICRAIS 2024, MIT Manipal (6–7 Nov 2024): Dr. Veerapraphap V and Mr. Chandra Shekar P
- IEEE ICDSNC 2024, SKIT, Bengaluru (20–21 Sept 2024): Mr. Chandra Sshekar P

Research Publications

- Dr. Basavaraj L & Anuradha M G published a paper “Low Cost and High-Speed Implementation of K-Means Algorithm for Image Analysis” in Journal of Information Systems Engineering and Management (Scopus Indexed) – Vol. 10, Issue. 18
- Ms. Anupama Shetter published a review article on “Emerging biomarkers in cancer diagnosis and prognosis: Novel approaches for precision oncology” in Oncology and Radiotherapy Journal (Scopus Indexed), Vol 18(9)
- Dr. Veerapraphap V published a paper on Automated raga recognition in Indian classical music using machine learning techniques in the Journal of Integrated Science and Technology (Scopus Indexed), Vol. 13 issue 1 2025.
- Dr. M. K. Prathibha – Transmutation of Conventional Fuel Based Two wheeler Vehicles into Electric Vehicles - (Scopus Indexed) – Journal of Mines, Metals and Fuels, 72(11): 1179-1185; 2024. DOI: 10.18311/jmmf/2024/45180
- Dr. M K Prathibha - Fluid-control codesign for paper-based digital biochips using volumetric memory networks: A predictive modelling approach in intergration of journals with vol. 103(Scopus Indexed)
- Mr. Chandra Shekar P presented Revolutionizing Multiplication: Implementing Vedic Sutra Principles in Multiplier Design at IACIS 2024 (Navkis College, Hassan) and Enhancing Glaucoma Detection through Deep Learning Algorithms at ICRASET 2024 (Adichunchanagiri University) – IEEE Digital Explore
- Mrs. Swetha K T – Paper presented paper “Optimized Audio Classification with Convolutional Neural Network Ensembles” at 2024 International Conference on Recent Advances in Science and Engineering Technology (ICRASET), B G Nagara, Mandya– IEEE Digital Exploresue. 4, 2025
- Ms. Anupama Shetter – Presented paper “Musical Instrument Classification Using Deep Learning CNN Models” at ICIICS 2024, Sharnbasva University – IEEE Digital Explore

- Mr. Guruprasad KN has published a paper on “Bluetooth Controlled Robotic ARM Rover” in the journal “International Journal Of Innovative Research In Computer And Communication Engineering (IJIRCCE)”, on May 2025
- Mr. Guruprasad KN has published a paper on “Agri Bot & Eco Pathogen Detection” in the journal “International Journal Of Innovative Research In Computer And Communication Engineering (IJIRCCE)”, on May 2025
- Mrs. Keerthi A Kumbar has published a paper on “Design and Modeling of Microstrip Patch Antenna for 5G – Mobile communication” in the journal “International Research Journal of Engineering and Technology (IRJET)”, on April 2025
- Mr. Pradeep Kumar Y has published a paper on “Noise Level Monitor and Controlling System” in the journal “International Research Journal of Engineering and Technology (IRJET)”, on June 2025
- Dr. Veerapathap V has published a paper on “Optimized Image Compression Using Multiple Compressed Sensing Techniques” and “Optimized Machine Learning Techniques for Precise Breast Cancer Detection in Mammograms” in SN Computer Science with volume 6, issue. 4, 2025
- Dr. Veerapathap V has published a paper on “Advanced Machine Learning Techniques for Prognostic Analysis in Breast Cancer” in Open Bioinformatics Journal, Vol. 18, 2025
- Dr. M. K. Prathibha Advanced Footstep Power Generation System, International Journal of Innovative Research in Computer and Communication Engineering, Volume 13, Issue 12, DECEMBER 2024.
- Dr. M. K. Prathibha Smart Watch for Health Monitoring System, International Journal of Innovative Research in Science, Engineering and Technology, Volume 13, Issue 12, DECEMBER 2024.

Student Achievements

- The Department of ECE won the Championship Rolling Trophy for Sports and Cultural events in connection with ATMEYA 2K25, held at ATME College of Engineering, Mysuru.
- Build with AI Demo Day, Growth School (22 Sept 2024) – Teja N & Tharun Gowda A V (7th Sem)
- 1st Prize in Hackathon, Sai Vidya Institute of Technology, Bengaluru (18 Nov 2024) – Shreyas Kulkarni, Sonu C, Shwetha (5th Sem)
- RTL to GDSII & RISC-V Workshop, Cambridge Institute of Tech (19–20 Nov 2024) – Attended by 7th sem students
- Science Expo - Srujana 2024, JSS Academy (21 Nov 2024) – 5th sem students
- Semiconductor Workshop, IISc Bengaluru (5–6 Dec 2024) – Tejas N
- TCS Tech Bytes Quiz, (1 Dec 2024) – Vishveshwar Bhargava S, Varun G Raj (7th Sem)
- 28-hour E-Minds Hackathon, GSSSCE, Mysuru (10–12 Dec 2024) – Participation by 7th & 5th sem students

-
- Logic Craft, organized by IEEE Mysuru Subsection (19 Oct 2024) – Geetha Bai, Bhoomika V, Harsha Vasappa Shatavaji, B N Harshith
- 23rd Karnataka State Wushu Championship, Senior group player at University of Horticultural Sciences, Bagalkote from 1st to 4th September 2024- Kushal.U
- Nisarga DR of ECE department represented University Baseball (women) Team for All India Inter University Championship 2024-2025
- Kushal.U of ECE department represented University Wushu (Men/women) Team for All India Inter University Championship 2024-2025
- Shreyas Shridhar Kulkarni of ECE department participated in project Exhibition “Vijnatham Utsav- 2025” at Sri Kshetra Adichunchanagiri, from 19/02/2025 to 20/02/2025
- Suchith, Srinath D Pol, Punya of 6th sem attended project exhibition at Adichunchanagiri University.

Workshops & Technical Events

- **Code - Connect:** Zonal-level technical event for diploma students (12–14 Dec 2024)
- **Tech Talk:** “Exploring the Tech Trio: AR, VR & AI” by Dr. Thotreingam Kasar (5 Nov 2024)
- **Sustainability Awareness Program,** aligned with AICTE points (8–9 Oct 2024) – Conducted by Ms. Seemanthini C
- **Technical talk:** “The Future of Embedded System: Trends, Challenges & Opportunities” by Mr. Pradeep N G and Mr. Sudheendra S, Logycent Musuru (14th March 2025)
- **Expert Talk:** “Semiconductor Future and Opportunities” by Mr. Sunil Kumar, Founder, Vivarthan Technologies (24th FEB 2025)

Project Showcase

- **Patent Filed:** “A Method for Detecting and Classifying Spinal Cord Tumors Using Neural Networks” (App. No: 202411057919) Inventors: Dr. Bhagyashree S. R. and Sheetal Garg Filed: 31 July 2024 | Published: 16 August 2024
- **Patent Filed & Granted:** “Enhanced System And Method For Accident Prevention In Underground Collieries” (App. No.202141045358) Inventors: Ms. Kalpana K,,Ms. Dhanusha T,Ms. Chandu D,Ms. Bhavana D C under the Guidance of Dr. Pavithra A C



ELECTRONICS & COMMUNICATION TOPPERS FOR THE ACADEMIC YEAR 2024-25

SNEHA M 2ND yr
(4AD23EC094) CGPA:9.38



V V RIYA VIJAY 2ND yr
(4AD23EC105) CGPA:9.12



TANUSHREE T R 4TH yr
(4AD21EC088) CGPA:9.58



P D DRUTHI 3RD yr
(4AD22EC069) CGPA:9.23



ANANYA S NAYAK 4TH yr
(4AD23EC105) CGPA:9.12



TEJASWINI D 3RD yr
(4AD22EC114) CGPA:9.14



PRIYA M 3RD yr
(4AD22EC076) CGPA:9.14



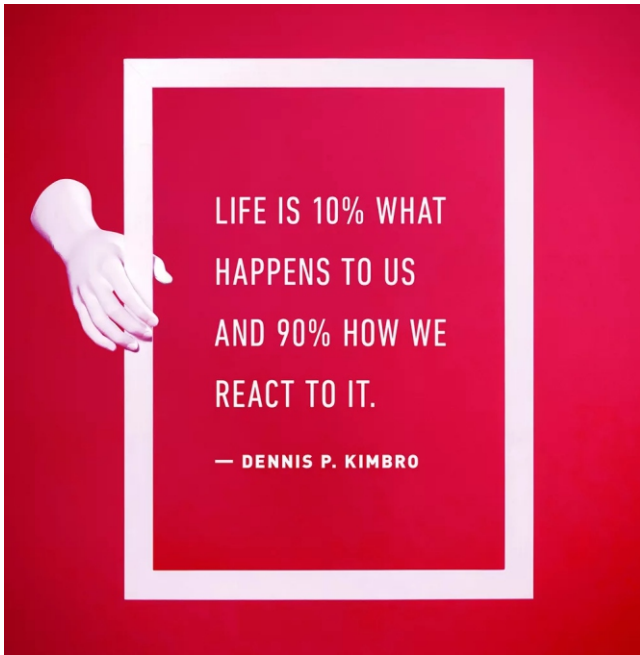

DEPARTMENT OF ELECTRICAL & ELECTRONICS ENGINEERING

DEPARTMENT OF EEE

ABOUT THE DEPARTMENT

The Department of Electrical & Electronics Engineering believes in imparting holistic education, where the student community is the focal point of the learning process. We offer a motivating environment for knowledge assimilation with a sense of social responsibility and human values. The department Undergraduate Program is Accredited by National Board of Accreditation (for second time up-to 2024-2025) and has well qualified and experienced faculty members with specialization in Power systems, Power Electronics, Energy Systems & Management, Computer Applications in Industrial Drives, Bio-Medical Signal Processing & Instrumentation and VLSI Design & Embedded systems. All the laboratories relevant to the program are established as per Visevesvaraya Technological requirement and the department is highly committed to bring-in the state of art laboratories to provide quality education for present challenging societal and industrial needs. We update and associate with training institutes to ensure that our students gain technical, interpersonal and communication skills.

To prepare our students for Industry-ready, the Department has MoU with Karnataka German Technical Technological Institute, Vidyut Automation, Innovaskill Technologies, Xponential orbit shifters, which provide Domain Specific Training in the area of Industrial Automation and Embedded system design. This enables the students to exhibit their Technical skills in the field of Automation and Embedded system design.

Vision of the Department

To create Electrical and Electronics Engineers who excel to be technically competent and fulfil the cultural and social aspirations of the society.

Mission of the Department

- To provide knowledge to students that builds a strong foundation in the basic principles of electrical engineering, problem solving abilities, analytical skills, soft skills and communication skills for their overall development.
- To offer outcome based technical education.
- To encourage faculty in training & development and to offer consultancy through research & industry interaction

KEY MILESTONES

- Ms. Safeena Shazia Secured 8th Rank in University with an average score of 84.55%
- NAAC A+ grade Accreditation in the first cycle.
- National Board of Accreditation (Term-I: 2019-2022; Term-II: 2022-2025)
- AICTE-MODROB Funding for Cyber security in Power Systems
- Funding from KTECH-NAIN for Project Portable Baby Incubator with Sleep Apnea Monitoring for Premature Infants
- Best Student Project under Karnataka State Council for Science and Technology(KSCST) for 3 Consecutive Years
- Financial Assistance for student Projects by VTU and KSCST.
- 98% and above Results in previous Six Graduating batches.
- Inter Institute Project Winners, Toycathon Semi-finalists, IIC-MHRD proposal, IICDC-DST participation etc.
- University level sports representation with gold medal.
- Average Placement: 70 % and above
- Our Alumni are entrepreneurs owning companies like FLARE LED, Madhu Electricals, Eagle Electricals, Manswi Infotech, nclues etc
- Alumni are working in premier MNCs like Oracle, IBM, Infosys, L&T, SIEMENS, JP Morgan, Skit.ai, J K Maini Aerospace, FCI OEN Connectors Limited, Carelon global, Kirsloskar etc and in government sector in KPTCL.

Faculty List

Sl.No.	Name	Qualification	Designation
1	Dr. Parthasarathy L	Ph.D	Professor and Head
2	Mr. Raghavendra L	M.Tech (Ph.D)	Associate Professor
3	Dr.Shakunthala C	Ph.D	Associate Professor
4	Dr. Sathish KR	Ph.D	Assistant Professor
5	Dr. Praveen Kumar M	Ph.D	Assistant Professor
6	Mr. Shreeshayana R	M.Tech (Ph.D)	Assistant Professor
7	Mr. Mohan M	M.Tech (Ph.D)	Assistant Professor
8	Ms. Swapna H	M.Tech (Ph.D)	Assistant Professor
9	Ms. Maria Sushma S	M.Tech	Assistant Professor
10	Mrs. Sowmyashree K S	M.Tech	Assistant Professor
11	Mrs.Kavyashree S	M.Tech	Assistant Professor
12	Mrs.Swathi C A	M.Tech	Assistant Professor

Technical Staff List

Sl.No.	Name	Qualification	Designation
1	Mr.Yasin Sharief	B.E	Foreman
2	Mr. Kushal R	Diploma	Instructor
3	Mr.Sunil Kumar M	Diploma	Instructor
4	Mr. MU Giridarshan	B.E	Assistant Instructor
5	Mrs.Sindhu N	Diploma	Assistant Instructor

Supporting Staff List

Sl.No.	Name	Designation
1	Mr. Swamy T	Attender

Department Activities

A. Faculty Activities

A.1 Faculty Development Programme Participated, AY 2024-25

SL. No.	Name of the Faculty	Title	Date	Organized by
1	Dr. Sathish K R	Innovation in Renewable Energy and its Application	9 th Sep to 12 th Sep 2024	SJCE, Mysuru
2	Mr. Raghavendra L			
3	Dr. Shakunthala C	6 days AICTE-ATAL FDP on Hands on approach for design and implement of Power Converters for Electric Vehicle Application	2 nd Sep to 7 th Sep 2024	NIE, Mysuru
4	Ms. Maria Sushma S			
5	Dr. Praveen Kumar M	FDP on Advanced Power System Analysis using ETAP	30 th Sep to 05 th Oct 2024	PESCE, Mandya
6	Mr. Shreeshayana R	Power Electronics Applications in Micro Grid using AI	9 th Dec to 14 th Dec 2024	Jain (Deemed-to-be) University, Bengaluru
7		Data Analytic and Visualization with Power BI and Tableau	9 th Sep to 13 th Sep 2024	CMRIT, Bengaluru
8	Mrs.Swathi CA	FDP on Research Pathway in EV Technology and Power System	26 th Aug to 31 st Aug 2024	SJBIT, Bengaluru
9	Mrs. Kavyashree S			
10	Dr. Shakunthala C	Indian Knowledge System	17 th Feb to 22 nd Feb 2025	VVCE, Mysuru
11	Dr. Shakunthala C Prof. Kavyashree S	Indian Knowledge System	5 th March to 7 th March 2025	ATMECE, Mysuru
12	Dr. Praveen Kumar M	Cyber Security Awareness and Emerging Technologies for Secure Social Media and Banking Applications	10 th March to 14 th March 2025	ATMECE, Mysuru
13	Prof. Raghavendra L Dr. Sathish K R	All Electric Aircrafts for Decarbonized Communities	26 th May to 28 th May 2025	IIT Goa
14	Prof. Swapna H	Advance Tools and Techniques for Research Methodology	02 nd June to 12 th June 2025	Research Foundation of India
15	Dr. Praveen Kumar M	Cyber Security Awareness and Emerging Technologies for Secure Social Media and Banking Applications	10 th March to 14 th March 2025	ATMECE, Mysuru

A.2 Workshop Participated, AY 2024-25

SL. No.	Name of the Faculty	Title	Date	Organized by
1	Mrs.Sowmyashree K S	Two-Day Hands-on Workshop on Microsoft Excel with AI and Chat GPT	29 th Nov to 30 th Nov 2024	Scroll-well
2	Ms.Swathi CA			
3	Dr. Praveen Kumar M Prof. Shreeshayana R Dr. Shakunthala C	Patent Drafting, Filing & Interpretation	12 th June to 14 th June 2025	ATMECE, Mysuru

A.3 MOOC Certifications

SL No.	Faculty Member	Course Title	Platform	Duration
1	Dr. Shakunthala C	Swayam - Introduction to Industry 4.0 and Industrial Internet of Things	NPTEL	12 Weeks Jul-Oct 2024
2	Ms. Maria Sushma S			
3	Mrs. Swathi CA			
4	Mrs. Kavyashree S			
5	Dr. Shakunthala C, Prof. Maria Sushma S, Prof. Swathi C A, Prof. Kavyashree S	Patent Filing in India	UDEMY	July 2025

A.4 Industrial Training:

SL No.	Faculty Member	Training Division	Company	Duration
1	Mr. Shreeshayana R	Product Design, Embedded System Design, IC Design.	Qualcomm, Bengaluru	29 th Sep 2024

A.5 Publications Details: Scopus Indexed/Google Scholar Journals

Sl. No.	Author	Paper Title	Conference/Journal Details	Indexing
1	Dr. Shakunthala C	Voltage regulation and reactive power compensation in EV-PV Grid environment	15 th International Conference on Advances in Computing Control and Telecommunication Technologies, pp. 5969-5975	Scopus
2	Mr. Raghavendra L Dr. Parthasarathy L	Analysis of Power Quality in Micro grid Systems with Renewable Energy Integration Utilizing Multi-Signal Discrete Wavelet Transform	International Journal of Renewable Energy Research, Vol.14, No.4, December 2024	Scopus
		Enhancing Power Quality in Microgrids with Integrated Distributed Energy Resources: A Comprehensive Analysis	Journal of Electrical Systems, Vol. 20 No. 3, 2024	Scopus
3	Dr. Sathish K R	A Smart Fire Rescue Bot Using Sensors and Arduino IDE	4th International Conference on Sustainable Expert Systems, ICSES 2024 – Proceedings pp. 33-37	Scopus
4		Harmonics and Voltage flicker investigation of different Electric Arc Furnace models on Power Systems	2024 International Conference on Electrical, Electronics and Computing Technologies, ICEECT 2024	Scopus
5		Power Quality Evaluation and Improvement in Electric Arc Furnace using UPQC	International Conference on Intelligent Algorithms for Computational Intelligence Systems, IACIS 2024	Scopus

6	Swapna H	The impact of immunotherapy on cancer treatment outcomes: Mechanisms, efficacy, and future directions	Oncology and Radiotherapy	Scopus
7	Mr. Shreeshayana R	GaN/GaN-graphene nanoribbon tunnel FET for bio-sensing	Physica Scripta, 2024, DOI: 10.1088/1402-4896/ad8c01, Impact Factor: 2.93, SJR: 0.441, H-index: 91	Scopus
8		Deep Learning for Early Detection of Pneumonia	Frontiers in Health Informatics, 2024, ISSN: 2676-7104, H-index: 7	UGC Care
9		Ergonomic Tremor Control Spoon for Parkinson's Disorder	ICCCNT, 2024, DOI: 10.1109/ICCCNT61001.2024.10726044	Scopus
10	Ms. Maria Sushma S	Impacts of Distributed Photovoltaic Units on Distribution System Power Quality	IJCRT Volume 12, Issue 9 th Sep 2024 ISSN: 2320-2882	Google Scholar
11	Ms. Kavyashree S	Equivalent Static and Response Spectrum Analysis for Plain Irregular and Composite structures using ETABS	Foundry Journal ISSN: 1001-4977 Volume 27 Issue 8	UGC Care
12	Dr. Shakunthala C	Enhancing Micro Grid Stability Hysteresis Current Control of Three Phase PV System	Emerging Second International Conference on Emerging Technologies	Scopus
13	Prof. Raghavendra L	Modeling and Positioning D-STATCOM using an Analytical Method Based on a Multi-objective Function to Enhance Micro grid Power Quality	Journal of The Institution of Engineers (India): Series B	Springer
14	Dr. Sathish K R	Review on Optimal Planning and Operation of Charging Stations for Electric Vehicles	International Journal of Applied Power Engineering (IJAPE)	Scopus
15	Dr. Praveen Kumar M	Structural engineering of EuAl ₂ O ₄ nano particles for advanced electrochemical dopamine electrochemical sensor	Journal Micro chemical Journal, Volume 215	WoS/ Scopus
16	Prof. Shreeshayana R	AI and ML-based Framework for Malware Detection in Cyber-Physical Contexts	Global Conference on Cognitive Computing And Communication Technology (GC T-2025) & DPU Tech Connect 1.0 organized in collaboration with IEEE Pune	Scopus
17	Prof. Shreeshayana R	Unsupervised CPS Anomaly Detection Using Isolation Forest with Adaptive Thresholding	International IEEE Conference on Computing, Communication And Networking Technologies (ICCCNT)	Scopus
18	Prof. Shreeshayana R	A Novel Deep Learning Architecture for Accurate Glioma Segmentation in Brain MRI	International IEEE Conference on Computing, Communication And Networking Technologies (ICCCNT)	Scopus
19	Prof. Shreeshayana R	Advanced Malware Detection Methods for Polymorphic Virus Identification	International Conference on Communication, Computing & Industry 6.0	Scopus
20	Prof. Swapna H	Urban Sound Classification with Convolutional Neural Network	2nd IEEE International Conference on Integrated Intelligence and Communication Systems ICIICS	Scopus
21		Challenges and Opportunities in Streaming Data for Quantum Encryption	2nd International Conference on Innovations in High-Speed Communication and Signal Processing (IHCSPP)	Scopus

A.6 Industrial Consultancy Services

Department of Electrical and Electronics Engineering is offering consultancy services to Government and industry, private organizations and other external institutions/sources for providing solutions to challenging problems and the amount generated is as follows.

Sl. No.	Name of the Consultant	Name of Consultancy Project	Consulting/ Sponsoring Agency	Revenue Generated (INR In Lakhs)	YEAR
1	Dr. Parthasarathy L Dr. Shakunthala C	1. 66kV Line Bay 2. 66kV Transformer Bay 3. 66/11kV 8MVA Transformer 4. 11kV Incomer 5. 11kV Feeders 6. Capacitor Bank 7. 66k V Potential Transformer & its Isolator 8. Earth Integrity & Stability 9. Station Auxiliary Transformer 10. ACBD, DCDB, Battery Charger etc	ELECTRO TECH, Mysuru	Rs.2,12,400/-	Aug-2024

A.7 Research Centre Details

The program has a Research Centre, to pursue Ph.D. The program has registered supervisors under VTU. Research supervisors are responsible for guiding and monitoring the progress of research scholars pursuing Ph.D. or Integrated Ph.D. programs.

Research Centre	Research Supervisor Name
Electrical and Electronics Engineering	Dr. Parthasarathy L
	Dr. Shakunthala C
	Dr. Sathish K R
	Dr.Praveen Kumar M

A.8 Faculty Achievements AY 2024-25

Sl. No.	Year	Activities	Name of the faculty
1	Sep-23	BoE. Member, PESCE Mandya	Dr. Parthasarathy L
2	Jun-23	BoS. SJCE, Mysuru	Dr. Parthasarathy L
3	March-24	Ph.D Awarded by VTU	Dr. Praveen Kumar M
4	Sep-24	Published a textbook titled "Fundamentals of Smart Grid Technologies and its Applications" by Scientific International Publishing House ISBN No: 978-93-6674-735-4.	Mr. Raghavendra L, Dr. Sathish K R and Ms. Swapna H
5	Sep-24	Best Teacher Award	Ms. Swapna H
6	Aug-24	Appointed as BoE. Member- VTU	Dr. Shakunthala C

A.9 Patent Details

Sl. No.	Author	Paper Title	Patent ApplicationNo.	Status
1	Mr. Raghavendra L	A Novel Deep Learning Based Automated Cyber security System And Method Thereof	202441024310	Published
2		Electrical Parameter Measuring Device for Electric Vehicles.	442355-001	Grant

B. Student Activities Conducted

B.1 Domain Specific Training Conducted

Academic Year	Batch	Training Level (DST)	Semester	Duration	No. of Students	Training Organization	Resource Person
202425	2021-25	Embedded System Design, Level-4	VII	50	24	Innovaskill Technologies Pvt Ltd, Bengaluru	Mr. Ravi CEO & Founder
202425	2021-25	Industrial Automation, Level-4	VII	50	28	KGTTI, Mysuru	Mr.Chandrashekar P Senior Engineer
202425	2022-26	Embedded System Design, Level-2	V	50	42	Innovaskill Technologies Pvt Ltd, Bengaluru	Mrs.Fathima Reenu Software Developer
202425	2022-26	Industrial Automation, Level-2	V	50	25	KGTTI, Mysuru	Mr.chandrashekar P Senior Engineer
202425	2022-26	Embedded System Design, Level-3	VI	50	41	Innovaskill Technologies Pvt Ltd, Bengaluru	Mr. Ravi CEO & Founder
202425	2022-26	Industrial Automation, Level-3	VI	50	25	KGTTI, Mysuru	Mr.Vishwanathan P Engineer
202425	2023-27	Industrial Automation Level-1	IV	50	38	KGTTI, Mysuru	Mr.Vishwanath P Engineer
202425	2023-27	Embedded System Level-1	IV	50	21	Innovaskill Technologies Pvt Ltd, Bengaluru	Ms.Fathima Reenu Engineer

B.2 Technical Talk Conducted

Sl No.	Date	Name of the Activity	Association	Participants Semester	No of Participants
1	12.05.2025	Technical Talk on Embedded Systems and Product Development	IEEE ATME Student Branch (STB:35744)	4 th Semester and 6 th Semester	59 Students 65 Students

The Department of Electrical and Electronics Engineering, ATME College of Engineering, Mysuru in collaboration with IEEE ATME Student Branch (STB:35744), organized an insightful Technical Talk on “Embedded Systems and Product Development” on May 12, 2025. The session was organised for students from the IV and VI semesters of the department.

The resource person for the event was Mr. Geethesh NS, Chief Operating Officer, DTRI, Mysuru, who shared his expert knowledge on the evolving field of embedded systems. He began with a detailed discussion on the software and hardware design of embedded systems, touching upon essential concepts such as validation and conformance testing

A key highlight of the talk was the case study titled “Operation Sindoor”, which illustrated the role of embedded systems in military and humanitarian missions. Mr. Geethesh showcased advanced technologies including drones equipped with thermal imaging, secure embedded radios, GPS tracking systems, portable smart medical kits, and real-time RADAR surveillance—all controlled by embedded processors.

These real-world examples demonstrated how embedded solutions can lead to efficient crisis management and risk reduction in conflict zones.

Mr. Geethesh also emphasized:

- The basic building blocks of embedded systems
- Three vital technical skills required in the field
- A comparative outlook on academic vs industrial projects
- The Product Development Life Cycle (PDLC) with a structured flowchart
- Real product samples developed by DTRI

The session was coordinated by Dr. Praveen Kumar M and Mr. Shreeshayana R, and was well received by all participants for its practical relevance and depth of content.



B.3 Industrial Visit

Sl No.	Date	Name of the Activity	Industrial Visit To	Participants Semester	No of Participants
1	10.03.2025	Industrial Visit	Sattegala Mini Hydel Power Station	6 th Semester	65 Students
2	14.05.2025	Industrial Visit	220kV kadakola substation	4 th Semester	59 Students

The Department of Electrical & Electronics Engineering, ATME College of Engineering, Mysuru had organized an Industry visit for 6th Semester students to Sattegala Mini Hydel Power Station, Boruka Power Corporation Limited, Sattegala village, Kollegala Taluk, Chamarajanagar District on 10th March 2025. The visit was intended to bridge the gap between theory and practice, addressing engineering attributes and to provide students with valuable practical insights into hydropower generation, Hands-on Exposure to Equipment & Technology, reinforce teaching and learning process.



The Department of Electrical and Electronic Engineering, ATME college of Engineering Mysuru, had organized a Industrial visit for 4th semester students to 220 kV kadakola Substation, Mysuru on 14th May 2025. The purpose of the visit was to gain an in-depth understanding of the infrastructure, operational processes, and technological aspects of the substation, which plays a pivotal role in the power distribution network.

B.3 Workshop Conducted

Sl No.	Date	Name of the Activity	Association	Batch	No of Participants
1	12 th Dec to 14 th Dec 2024	Three Day workshop on LASER CNC cutting and 3D Printing	ISTE	2021-25	52

B.5 Social Connect and Responsibility Activity

The second-year students had an academic visit to the in-house Sewage Treatment and Rainwater Harvesting Plants under the Social Connect Responsibility initiative on 28/09/2024 and 30/10/2024. The program offered technical insights into sustainable water management systems, promoting environmental responsibility and enhancing students' understanding of resource conservation through exposure to practical engineering applications.



C. Student Achievements

C.1 Karnataka State Council for Science and Technology Student Project Sponsorship

Sl No.	Proposal Reference No.	Project Title	Name of the Guide(S)	Name of The Student(S)
1	48S_BE_6160	ERGONOMIC PORTABLE RADIANT WARMER AND SLEEP APNEA MONITORING DEVICE FOR NEONATAL CARE IN MATERNITY CENTRES	Mr. Shreeshayana R Dr. Parthasarathy L	Mr. Mohammed Harmain Ms. Fathima Sadaf, Mr. Mohammed Sabir Mr. Vivek H K
2	48S_BE_6193	SEMI-AUTOMATED WASTE SEGREGATION SOLUTION FOR EFFICIENT URBAN DOMESTIC WASTE MANAGEMENT	Dr. Praveen Kumar M Mr. Shreeshayana R	Mr. Jeevan N Ms. Manogna K V Mr. Arun Kumar K P Mr. Shashank N M
3	48S_BE_6201	ANAEROBIC DIGESTION OF CANTEEN WASTES FOR BIOGAS PRODUCTION	Mr. Raghavendra L Dr. Parthasarathy L	Mr. Shivaprasad B M Mr. Sandeep H M Mr. Sanju T C Mr. Sumanth Naika
4	48S_BE_6296	WRIST DISARTICULATION PROSTHESIS FOR AMPUTEES TO SUPPORT REHABILITATION	Mr. Shreeshayana R Dr. Parthasarathy L	Mr. Charan Kumar G V Ms. Dhanushree H K Mr. Mohammed Azlaan Ms. Sinchana K

C.1.B National Conference Participation

The Department of Electrical and Electronics Engineering 6th semester project group students had participated in the National Conference on Intelligent Energy System (NCIES-2025) on 12th April 2025 at GSSSIETW, Mysuru.

SI No.	Team Mentor	Project Title	Name of The Student(S)
1	Prof. Maria Sushma S	Automatic Smart Vacuum Cleaner	Ms. Likitha B M Mr. Mahadevaswamy Mr. Sujan A N
2	Prof. Swathi C A	Transformer Performance Monitoring using IoT	Ms. Sneha S Mr. Manoj H S Mr. Sudeep H K
3	Prof. Kavyashree S	Smart Energy meter for water flow monitoring system using IoT	Mr. Sanjay K Mr. Manoj V Ms. Laskshmi K Ms. Trisha G

C.2 PARTICIPATION IN INTERINSTITUE EVENT

The 4th & 6th Semester Student of the Department of Electrical and Electronics Engineering had participated in the Inter-College Hackathon on IoT based problem statements in domain's Healthcare, Agriculture, Transportation held in MRIT Mysuru on 11th April 2025, Team Lead by Ms. Sangeetha K A was awarded with Consolation Prize with a cash.

The Table Mentioned below provides information of student participants in MRIOTHON-2025

SI No.	Semester	Team Mentor	Project Title	Name of The Student(S)
1	VI	Prof. Shreeshayana R	IOT AND GPS BASED SOLDIER POSITION TRACKING AND HEALTH MONITORING SYSTEM	Mr. Gagan Keerthi P N Mr. Ganapathi S P Ms. Rakshitha A M Ms. Suchithra H G
2	VI	Dr. Praveen Kumar M	ACTIVE PLANT WALL FOR GREEN INDOOR CLIMATE BASED ON CLOUD AND INTERNET OF THINGS	Ms. Sangeetha K A Ms. Sinchana I M Mr. Sanjay K Mr. Sujan M
3	VI	Prof. Shreeshayana R	RAKSHAK: SMART HEALTH-BAND FOR ELDERLY AND ALZHEIMER'S CARE	Ms. Dhanuvidyashree Ms. Sanjana B R Mr. Sharathmurthy N S Mr. Chinthan A D
4	IV	Dr. Praveen Kumar M	IOT AND GPS BASED SOLDIER TRACKING AND HEALTH MONITORING SYSTEM	Ms. Manisha P Gowda Ms. Impana K P Mr. Ujwal V Mr. Lakshmisha M
5	IV	Dr. Praveen Kumar M	IOT AND GPS BASED SOLDIER POSITION TRACKING AND HEALTH MONITORING SYSTEM	Ms. Meghana M R Ms. Likitha B G Mr. Shashank Kumar M Mr. Deekshith U
6	IV	Prof. Shreeshayana R	SMART BUS SYSTEM	Ms. B. Bhuvana, Mr. Mohammed Arban Mr. Chiranth S Ms. Nisarga H

C.2.B Project Competition Participation

The 6th & 8th Semester Student Groups of the Department of Electrical and Electronics Engineering had participated in the Inter-College Technical Project Competition at Various Institutions.

Sl No.	Team Mentor	Project Title	Semester	Name of The Student(S)	Venue
1	Dr.Praveen Kumar M	Smart Classroom Automation	VI	Sunil Kumar Sharathmurthy N S Bhavana R Sneha M	VRIDDHEE-2025 State Level Project Competition, VVCE, Mysuru 29-03-2025
2	Ms. Swapna H	Automatic Washroom Sanitizing System	VI	C Dhanush Ananya M Anushree Mc Manoj B	
3	Prof. Shreeshayana R	Portable Baby Monitoring System	VI	Gagan Kirthi P N Ganapathi S P Rakshitha A M Suchitra H G	
4	Prof. Raghavendra L	Biogas Production From Canteen Waste	VIII	Sumanth Naika M S	
5	Prof. Swapna H	Solar Grass Cutter	VI	Ms. Keerthana H N Mr. Chandu N Ms. Thilaka	UDBHAV-2025 MRIT Mysuru on 12 th May 2025
6	Prof. Swapna H	Domestic Illumination Using Solar	VI	Mr. C Dhanush Mr. Sharath Murthy Ms. Sneha M Ms. Bhavana R	
7	Prof. Swapna H	Solar UPS Based Green House Climate Control	VI	Mr. Adarsh S Mr. Chandan K Ms. Anush H G Ms. Chaithanyashree M	
8	Prof. Swapna H	Renewable Energy Based Home Automation System	VI	Ms. Likitha B M Ms. Likitha M	

C.3 State Level Technical Fest

The Department of Electrical and Electronics Engineering at ATME College of Engineering (ATMECE), Mysuru, successfully organized the State-Level Technical Project Competition "Avagamah – 2025" on May 21st. The event was conducted in association with The Institution of Engineers (India) and the IEEE ATME Student Branch, drawing enthusiastic participation from final and pre-final year students across various engineering institutions in Karnataka.

Held in both on-campus and online formats, the competition provided a platform for young innovators to present their projects focused on energy, sustainability, automation, healthcare, and emerging technologies. The day-long event featured the exhibition of Capstone projects, with approximately 52 teams participating from various districts of Karnataka.

The event was coordinated by Dr. Praveen Kumar M, Prof. Raghavendra L, and Prof. Shreeshayana R, with active support from the faculty and student volunteers. The winners were felicitated with certificates and cash prizes in recognition of their efforts and creativity.



C.4 Meritorious Award for Toppers

SL.No.	Award	USN	Name	SGPA
1	Skilltech Merit Award, Branch Topper	4AD21EE020	VAISHNAV T A	9.32
2	Manjulamma Memorial Award, Highest Marks in Electric Circuit Analysis Course	4AD21EE020	VAISHNAV T A	93/100
3	Sai Yeshorathna Memorial Award, Branch Second Topper	4AD21EE001	ANJANA C V	9.14
4	Siddamma Lakshmana Shetty Memorial Award Branch-Topper, Lateral	4AD22EE404	CHARAN KUMAR G V	8.42



D. Career Guidance and Placement

Placement training plays a major role in shaping up the career goals of students. The Training Division of the ATMECE Placement Cell offers training with a vision to cater to the requirement of industries. Training etiquette like Business English, Personality Development, logical & verbal analysing ability, Group Discussion, Resume writing etc are expected from graduates. Keeping this key aspect into consideration, it is realized that training is important to create an exposure, enhance skill set, build confidence amongst engineering students to enhance their employability and achieve good placement in various Industries.

D.1 Placement Training Activity

SL.No.	Training Institute/Vendor	Semester	No. of Students
1	Aptitude Verbal & Reasoning-I In-House Training	IV	59
2	Aptitude Verbal & Reasoning-III In-House Training	VI	65
3	Genplus Training & Consulting Service Private Limited	VII	52

D.2 Placement Report

SL.No	USN	NAME	DESIGNATION	COMPANY PLACED
1	4AD21EE021	VARSHA S	Software Developer	Skit.ai
2	4AD21EE003	DARSHITH S	Trainee Operator	J K Maini Aerospace
3	4AD22EE403	ARUNKUMAR KP	Trainee	FCI OEN Connectors Limited Bangalore
4	4AD22EE408	MANASA B L	Trainee	FCI OEN Connectors Limited Bangalore
5	4AD22EE404	CHARAN KUMAR G V	Technical Maintenace	Carelon global
6	4AD22EE423	SUNIL P	Technical Maintenace	Carelon global
7	4AD22EE402	ARCHANA H L	Sales Executive	Kirsloskar
8	4AD21EE019	TIBA IRUM	Aeronautical Development Agency	Intern

Sports Achievers

1. Mr. Vikyath K V (4AD22EE054) has secured winner Place in VTU Inter Collegiate Wrestling Men 70 Kg Inter Collegiate State Level Tournament held at Global Academy of Technology from 15.11.2024 to 16.11.2024

2. Mr. Harish Kumar G (4AD22EE022)

- Secured First place in Soft Ball, the competition held at SBRRMFGC on 25.11.2024 to 26.11.2024.
- Secured Third Place in VTU Softball Inter Collegiate held at SJM, Institute of Technology Chitradurga from 13.11.2024 to 14.11.2024.
- Secured Winner Place in VTU softball Men Inter Collegiate Rest of Bengaluru Division Level Tournament held at SJM, Institute of Technology Chitradurga from 11.11.2024 to 12.11.2024.

3. Mr. Harshith A P (4AD22EE023) has Secured Winner Place in VTU softball Men Inter Collegiate Rest of Bengaluru Division Level Tournament held at SJM, Institute of Technology Chitradurga from 11.11.2024 to 12.11.2024

4. Ms. Nayana M V represented Softball Institute Team and VTU Team Member



Nayana M V



Vikyath K V



Harshith A P



Harish Kumar G



Department Toppers for AY 2024-25

I YEAR



SARAHA S R
4AD24EE030
CGPA-9.25



MANYA
4AD24EE016
CGPA-9.25

II YEAR



SACHITH GOWDA S R
4AD23EE034
CGPA-8.95



MANOJ M N
4AD23EE016
CGPA-8.73

III YEAR



DHANUVIDYASHREE
4AD22EE017
CGPA-8.83



SUCHITHRA H G
4AD22EE003
CGPA:8.8

IV YEAR



VAISHNAV T A
4AD21EE020
CGPA- 9.32



ANJANA CV
4AD21EE001
CGPA-9.17



DEPARTMENT OF MASTER OF BUSINESS ADMINISTRATION

Launch of MBA Program at ATME College of Engineering, Mysuru

ATME College of Engineering, Mysuru, proudly expanded its academic offerings by launching Post Graduate Programs, among which the Master of Business Administration (MBA) program stands out prominently. Initiated in the academic year 2024-25, this two-year MBA program is designed to be more than just a degree. It is a transformative journey aimed at shaping future leaders, innovators, and strategists who are well-prepared to tackle the challenges of a dynamic global business environment.

Program Vision and Objectives

The MBA department envisions developing visionary leaders with exceptional business acumen, cultural awareness, social responsibility, and global competence. The goal is to nurture graduates who will drive innovation, inspire positive change, and contribute meaningfully to the sustainable development of society.

The Department of Master of Business Administration (MBA) officially commenced its academic activities for the inaugural batch on 16th December 2024, welcoming 24 students. The Department prioritizes deep understanding and practical application of concepts, ensuring learning goes beyond examinations to become a lifelong asset.

Innovative Learning Activities

To enhance holistic development, the department incorporated weekly personality development activities into the curriculum. These included self-introduction exercises, topic-oriented presentations, formal letter writing, resume drafting, motivational video sessions, brand identification, and newspaper analysis. These activities are aimed at improving communication skills, building confidence, and preparing students for professional and social interactions in real-world scenarios.

Faculty

The faculty team is composed of individuals with strong academic backgrounds and a passion for teaching. The department is currently headed by Dr. Oscar Abhishek, Associate Professor, who brings a wealth of industry and academic experience and leadership to the team. The faculty team comprises of two Assistant Professors – Ms. Lakshmi M R and Ms. Pallavi – both known for their effective teaching methodologies and commitment to student development. Additionally, the department benefits from the expertise of visiting faculty member Ms. Jeevitha P., who contributes her knowledge to enhance.

A snapshot of programs conducted during the first semester

- Orientation Program: A comprehensive orientation session was held for MBA and MCA first-year students to acquaint them with the college's academic programs, organizational structure, and policies. This was conducted in the college auditorium.



- Industry Visit: Students visited VIMA RUBBERS PVT LTD, a small-scale ancillary industry specializing in rubber flaps manufacturing. This visit offered insights into the role of ancillary industries in supporting large corporations such as JK TYRES. Students observed the complete manufacturing process and learned about industry establishment procedures, including land acquisition, registration, and loan procurement.



- **“Illuminate” 3.0 Program: MBA students participated in the inspiring “Illuminate” event, celebrating India's engineering marvels and innovation. Distinguished speakers like Mr. Srikanth Nadhamuni, Founder & CTO of Aadhar, and Ms. Gayathri Chauhan, Founder & CEO of Buzz on Earth, shared their success stories and highlighted the importance of innovation in today's business landscape.**



- **Workshop on MS Office Tools: A practical, hands-on workshop on MS Word and MS Excel was organized in February, conducted by Dr. Avinash, Professor & Head, Department of Chemistry ATME College of Engineering. The workshop spanned two sessions, focusing on key operational skills essential for business documentation and data management.**

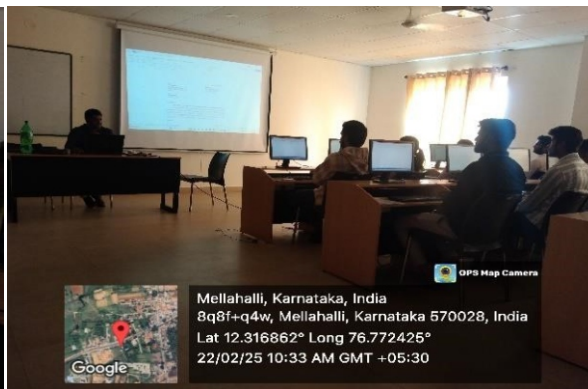

Co-Curricular Activities and Assessments

Students actively participated in seminars, presenting selected topics via PowerPoint, which contributed to their internal assessments. This exercise



fostered research skills, public speaking, and confidence. In addition, they also took active part in management games, quizzes etc., which were conducted to build confidence and team spirit among them.

Placement and Training Support

The Training and Placement Office at ATMECE offers dedicated placement assistance to MBA students. In their first year, students underwent 36 hours of soft skills training over 16 days, facilitated by industry experts. The sessions covered team building, time management, interview grooming, success strategies, behavioral skills, and communication etiquette. These interactive, activity-based sessions received enthusiastic participation and motivated the students.



Project Work and Internship

MBA students engage in mandatory societal projects during their semester breaks, addressing relevant social issues through primary or secondary data collection and analysis. Additionally, internships are undertaken between the second and third semesters, providing practical industry exposure, with reports submitted upon completion. A major academic project aligned with their specialization is completed and reported at the end of the fourth semester, ensuring application of theoretical knowledge to real-world business challenges.

The launch of the MBA program at ATME College of Engineering Mysuru marks a significant milestone in the institution's academic journey. With a focus on experiential learning, leadership development, and industry integration, the program is successfully nurturing a new generation of business leaders equipped to meet contemporary challenges with innovation, integrity, and social responsibility. The active participation of students in various academic, cocurricular, and industry-oriented activities demonstrates the program's commitment to holistic education.

**Appearing better than others is always dangerous,
but most dangerous of all is to appear to have no
faults or weaknesses.**

- Robert Greene

DEPARTMENT OF MASTER OF COMPUTER APPLICATIONS

ABOUT THE DEPARTMENT OF COMPUTER APPLICATIONS

In today's technology-driven world, computer applications play a vital role in every aspect of life from communication and information access to business operations and innovation. Recognizing this growing importance, the Department of Computer Applications aims to deliver excellence in computing education through a blend of theoretical knowledge, practical exposure, and industry-oriented learning.

The department offers two programs — Bachelor of Computer Applications (BCA) and Master of Computer Applications (MCA). The MCA program was established in 2023 with an intake of 60 students, later enhanced to 120 in 2024, reflecting the rising demand for skilled computing professionals. The BCA program, introduced in 2024, provides a strong foundation for undergraduates aspiring to build successful IT careers.

A team of highly qualified and experienced faculty leads the department, ensuring academic excellence and holistic student development. The curriculum, designed in alignment with VTU and approved by AICTE, emphasizes Outcome-Based Education (OBE) and hands-on learning through labs, projects, and case studies.

To enhance employability, the department offers comprehensive placement training programs that prepare students for industry expectations through aptitude sessions, technical workshops, and mock interviews. It also collaborates with industry experts for guest lectures, seminars, internships, and MoUs with IT companies. Through its commitment to quality education and research, the department shapes competent professionals ready to meet global IT challenges.

Ethnic Walk Highlights Women's Day at ATME College

As part of the Women's Day celebrations, ATME College of Engineering organized a colorful and spirited Ethnic Walk to honor culture, tradition, and womanhood. The event saw enthusiastic participation from students who walked the ramp in graceful ethnic attire, representing the rich diversity of Indian heritage. The Ethnic Walk was a true celebration of confidence, elegance, and cultural pride, adding charm and vibrance to the Women's Day festivities on campus.



A Graceful Win at the Women's Day Ethnic Walk



Adding charm and elegance to the Women's Day celebrations, the much-anticipated Ethnic Walk event showcased the beauty of tradition and cultural pride. Among the many participants who walked with confidence and grace, Rubiya Tashwin Begum stood out and was rightfully crowned the Winner of the Ethnic Walk Competition. Dressed in stunning ethnic attire and carrying herself with elegance, she truly embodied the spirit of the occasion. Her victory not only celebrated her individuality but also highlighted the significance of honoring cultural heritage in modern times.

National Conference Participation

Mr. Manikanta participated in the National Conference on Emerging Trends in Science & Technology for Ecological Conservation (ETSTEC-2025) held on 14th February 2025 at Surana College (Autonomous). The participant presented a paper/poster titled: "Development of an AI-Based Predictive Modelling System for Microplastic Pollution : Analyzing Pollution Sources, Effective Management, and Mitigation Strategies."

Organized by the Department of Science & Technology, Government of Karnataka, in association with KSTA, the event provided a great platform to showcase innovative ideas for environmental sustainability through the use of AI.

Mr. Manikanta's research paper titled "Neuroscientific Insights into the Cognitive Benefits of Mantra Chanting" has been published in

the International Research Journal on Advanced Engineering and Management (IRJAEM), Volume 03, Issue 05, May 2025. The paper explores the cognitive effects of mantra chanting through a neuroscientific lens.



Go Green Initiative – Campus Sustainability Drive

- The Go Green Drive at ATME College of Engineering was an inspiring environmental initiative aimed at promoting sustainability and creating eco-awareness among students and staff. The event included tree plantation, cleanliness drives, and awareness campaigns on reducing plastic use and conserving natural resources.
- Organized by the Eco Club in collaboration with NSS volunteers, the drive encouraged students to take responsibility for protecting nature. Saplings were planted across the campus, and informative sessions were held to educate participants about climate change, renewable energy, and waste management.
- The initiative successfully highlighted the importance of "going green" and making small, meaningful changes for a healthier planet. It also fostered a strong sense of environmental responsibility among young minds.



- Create awareness about environmental conservation
- Encourage sustainable practices on campus
- As part of our commitment to environmental sustainability, our college organized a "Go Green" activity week aimed at spreading awareness and promoting eco-friendly practices among students and staff. The event included tree plantation drives, clean-up campaigns, plastic-free campus pledges, and recycling workshops.
- Contribute to a greener and healthier planet.
- Students actively participated by planting over 100 saplings, switching to reusable bottles, and attending sessions on waste management and climate change. The event highlighted the importance of collective efforts in conserving nature and making our campus greener and cleaner.
- Motivate students to become eco-conscious citizens.
- The initiative received overwhelming support and has inspired many to adopt greener lifestyles.

KSOU – Illuminate

The "Illuminate" event conducted at Karnataka State Open University (KSOU) Mysore, was an insightful and engaging program that brought focus to one of the most significant aspects of India's digital infrastructure—Aadhaar authentication and detection.

Main Theme

"Aadhaar Authentication & Detection – Strengthening Digital Identity"

Event Highlights

Objective

The event aimed to spread awareness and showcase innovations in the field of biometric authentication, fraud detection, and the integration of Aadhaar into various systems such as banking, education, and public services.

Participants

Students from various departments, faculty members, tech experts, and guests from UIDAI and cybersecurity fields. Activities Included

- Seminars & technical sessions on how Aadhaar authentication works.
- Demonstrations on e-KYC, fingerprint and iris-based identity matching.
- Discussions on cybersecurity and data privacy.
- Project displays and poster presentations by students.
- Awareness quiz & panel discussions on ethical and legal implications of biometric systems.



SOFT SKILLS

Soft skills are personal attributes that enable effective interaction and collaboration with others. They are crucial for success in the workplace and beyond, as they complement technical skills and enhance overall performance.

Soft skills are an essential part of improving one's ability to work with

others and can have a positive influence on furthering your career. Our ATME college of Engineering provides us a great opportunity to get involved in SOFT SKILLS training to get an upgrade in personal and professional life.



What we have learnt during SOFT SKILLS training :

1. Communication:

Soft skills training empowers individuals to interact respectfully and persuasively. Training includes verbal, non-verbal, and written communication. Listening actively is as important as speaking effectively. Body language, tone, and clarity of message matter greatly. A well communication helps individuals to express ideas clearly and confidently.

2. Teamwork:

Teamwork teaches individuals how to collaborate and work effectively in groups. Through teamwork, participants learn trust, cooperation, and responsibility. Teamwork training builds leadership qualities and decision-making skills.



3. Time management:

It enables individuals to plan tasks effectively and Meet deadlines. Proper time management leads to higher productivity and reduced stress. It helps in setting priorities and achieving both short- and long-term goals. Techniques like scheduling, goal-setting, and time blocking are emphasized. Managing time wisely improves focus, decision-making, and efficiency.



4. Adaptability:



Soft skills training helps individuals embrace change with a positive mindset. Participants learn how to stay flexible in different roles and environments. Training includes simulations, role-plays, and real-life scenarios.

5. Leadership:



Soft skills training shapes leaders who adapt and innovate. It prepares individuals to handle roles in academics, careers, and communities. Leadership training builds initiative and accountability in every individual. Strong leadership drives success at both personal and organizational levels.

6. Creativity:

Creativity is a valuable soft skill that enables individuals to generate innovative ideas, solutions, and approaches. It involves thinking outside the box, making connections between seemingly unrelated concepts, and finding novel solutions to complex problems.

Soft skills are not just 'nice to have'; they are essential for navigating the complexities of the modern workplace and achieving lasting success.

In closing, remember that mastering soft skills is a continuous journey of growth and adaptation.



DEPARTMENT OF MECHANICAL ENGINEERING

Department of Mechanical Engineering

The Department was established in 2010 with the intake of 30 students and present intake is 30 students affiliated to Visvesvaraya Technological University. The Department has a total built area of 2000 sq. m. with well-equipped laboratories and state of the art facilities in order to foster the growth of students.

The Department is recognized as Research Centre by VTU during 2015-16. The Faculties of the Department are actively involved in research and consultancy works in the areas of Composite Materials, Fracture Mechanics, Fuels & Lubricants, Energy Systems Engineering and Renewable Energy.

The department strives to inculcate the young graduates with leadership, management and technical skills. In the department faculty encourages student to take up internship, industrial visit, workshop, and seminar and involves student in various curricular and co-curricular student development activities. The department is equipped with state of the art laboratories and is upgrading with change in technology.

Vision of the Department

To impart excellent technical education in mechanical engineering to develop technically competent, morally upright and socially responsible mechanical engineering professionals.

Mission of the Department

- To provide an ambience which impart excellent technical education in Mechanical Engineering.
- To enable the students to acquire skill development, knowledge of Research and recent trends in mechanical engineering which will engage them in lifelong learning.
- To engage students in co-curricular and extra-curricular activities to impart social & ethical values and imbibe leadership quality.

Program Educational Objectives (PEO's)

PEO 1: Graduates will be able to have successful professional career in the allied areas and be proficient to perceive higher education.

PEO 2: The Graduates will attain the ability to understand the need, technical ability to analyze, design and manufacture the product.

PEO 3: Work effectively, ethically and socially responsible in allied fields of mechanical engineering.

PEO 4: Work in a team to meet personal and organizational objectives and to contribute to the development of the society in large.

Program Specific Outcomes (PSO's)

PSO 1: Ability to apply and interpret the acquired mechanical engineering knowledge for advancement in Industrial, Societal, and Environmental arenas.

PSO 2: Ability to meet the needs of Industries in the field of design, manufacturing and testing using mechanical engineering software.

Memorandum of Understanding (MoU)

A memorandum of understanding is an agreement between Mechanical Department and other organizations outlined in a formal document. It is not legally binding but signals the willingness of the parties to move forward with a contract.

- Hindustan Spring MFG Co, Mysuru
- Lakshmi Springs & Pressings, Mysuru
- Universal Automobiles & Dairy Products, Mysuru
- Government Tool Room & Training Centre (GT&TC), Mysuru
- Karnataka German Technical Training Institute (KGTTI), Mysuru
- CAD DESK, Mysuru

FACULTY LIST

Sl.No.	Name	Qualification	Designation
1	Dr. Srinivasa K	Ph.D	Professor & Dean (Student Affairs)
2	Mr. Ravikumar S	M.Tech	Associate Professor
3	Mr. Devaraj M R	M.Tech	Associate Professor
4	Dr. Chethan S	Ph.D	Associate Professor & Head
5	Dr. Mohanakumara K C	Ph.D	Assistant Professor
6	Dr. Chetan S	Ph.D	Assistant Professor
7	Mr. Raghu	M.Tech (Ph.D)	Assistant Professor
8	Mr. Niranjan kumar V S	M.Tech (Ph.D)	Assistant Professor
9	Mr. Rohith S	M.Tech (Ph.D)	Assistant Professor
10	Mr. Hemanth B R	M.Tech (Ph.D)	Assistant Professor
11	Mr. Sukruthsagar B P	M.Tech	Assistant Professor
12	Mrs. Anoosha	M.Tech	Assistant Professor

TECHNICAL STAFF LIST

Sl.No.	Name	Qualification	Designation
1	Mr. Madesha S	Diploma	Foreman
2	Mr. Ravikumara M P	Diploma	Instructor
3	Mr. H C Chidambara	ITI Draft-man	Assistant Instructor
4	Mr. Pradeepkumar K B	ITI	Mechanic

SUPPORTING STAFF LIST

Sl.No.	Name	Designation
1	Mr. Lohithkumar	Lab Assistant
2	Mr. Nagendra R	Lab Assistant
3	Mr. Ananda C	Lab Assistant

Domain Specific Technical Training (DST)

Academic Year	Training Level(DST)	Semeste	Duration (hours)	Domain	No. of Student	Training Institute	Resource Person
2024-25	Level-1	IV	48	Design Engineering	12	KGTTL, Mysuru	Prof. Chandrashekar P Senior Engineer
				Automation/ Robotics/ Mechatronics	8		Prof. Manasa Engineer
2024-25	Level-3	VI	50	Design Engineering	12	CAD DESK, Mysuru	Prof. Jayaram/Ritish Engineer
2024-25	Level-4	VII	50	Design Engineering	12	CAD DESK, Mysuru	Prof. Jayaram/Ritish Engineer

INDUSTRIAL VISIT

Department of Mechanical Engineering has arranged industrial visit to 3rd and 5th semester students on 04.12.2024 as part of Industry-Institute interaction. The industry visited is OTR Plant, JK Tyres Industry Ltd. Mysuru.

JK Tyres, OTR Plant Manager-HR received the students and briefed about the company and production activities through videos and PPTs at meeting room. After the presentation, the students took to the shop floor where production activities are being carried out. While taking the students at different sections in the shop floor, the supervisors explained the production processes of ultra large tyres which are meant for off the road



(OTR) services. The students had effective interactions with the supervisors about the number of parameters and precautions to be taken care in order to get defect free tyres in their productions.



Department of Mechanical Engineering has arranged industrial visit to 3rd and 5th semester students on 04.12.2024 as part of Industry-Institute interaction. In this regard visited the Training centre and production section at GTTC Mysore Centre, Mysuru.

The students visited the Measurement and Metrology lab, Automation lab (PLC, SCADA) and Robotics section. The respective lab trainers demonstrated their respective labs and training facilities available to upgrade knowledge and skill

sets to prepare students industry ready.

The objective of this visit was to introduce the students to the industrial training and production activities that are being carried out at training centre and it's production section as this kind of visits supports.

3-day workshop on “CNC Laser Cutting and 3-D printing”

Dates: 12th to 14th Dec. 2024 at Dept. of ME, ATMECE, Mysore

Three day workshop on CNC Laser Cutting and 3-D printing was organized by the Department of Mechanical Engineering in association with ISTE student chapter of ATMECE. The participants were 5th semester and 3rd semester students of mechanical Engineering department. The workshop was conducted from 12th Dec to 14th Dec 2024.

The Resource persons were Dr. Mohanakumara K C, Asst. prof. Department of Mechanical Engineering, Mr. Renuka Prasad G P, Founder & CEO, Dhatri Solutions, Mysuru, and Mrs. Bharathi, Manager (Technical) CIPET, Mysuru.

Inauguration of the workshop was conducted on 12th dec 2024 at ME-seminar hall. The chief guest of the function was Mr. Renuka Prasad G P, Founder & CEO, Dhatri Solutions, Mysuru, presided by Dr. Basavaraj L, honorable Principal ATMECE. Dr. Chethan HoD Mech dept. welcome all and Dr. Mohanakumara K C briefed about the objectives of the workshop. In his inaugural address Dr. Basavaraj L stressed upon the importance of skill development and advised all participants to make use of the opportunity.

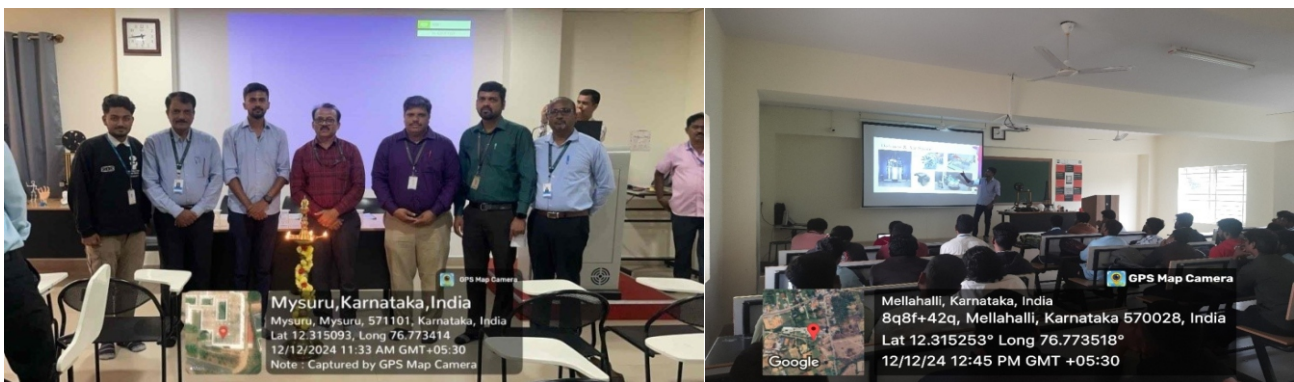

One-Day Workshop on “Introduction to Limits, Fits& Tolerances and Geometrical Dimensioning& Tolerancing (GD&T)”

A One-day workshop on "Introduction to Limits, Fits& Tolerances and G D & T" was organized by Department of Mechanical Engineering, ATMECE in association with ISTE-Student Chapter, on 15th May 2025. The participants were the students of IV and VI semester Mechanical Engineering Department. Workshop had two sessions-Theory Sessions in the morning by experts at the college and Hands-on session in the afternoon at GTTC, Mysuru.



The workshop was inaugurated by C M Aswathappa at 10:00am at Seminar Hall E106. Mr. V A P Sarma, Dr. Srinivasa K, Prof. and Dean-Student Affairs, and Dr. Chethan S, HOD of ME Dept. were present during the occasion. Dr. Chethan S welcomed



the speakers and all other dignitaries, to the inaugural program. Dr. Chethan S, HOD, highlighted the importance of learning and gaining knowledge on the above-mentioned topic which is required in the field of Design and Manufacture.

Technical Talk on “Design Engineering for Innovation: Creating Tomorrow's Technologies Today”

Department of Mechanical Engineering, ATMECE in collaboration with Institutions Innovation Council – ATMECE has organised a Technical Talk on “Design Engineering for Innovation: Creating Tomorrow's Technologies Today” for the students of the Mechanical Engineering department on 18th December 2024.

The keynote speaker for the session was Mr. Jayaram, the Head of the Center at CADDESK, Mysuru, a renowned expert in design engineering. With years of experience in the field, Mr. Jayaram provided valuable insights into cutting-edge techniques and tools that are shaping the future of technology.



The talk emphasized the importance of integrating innovative design processes into engineering practices to meet modern-day challenges. Mr. Jayaram shared real-world applications and case studies, highlighting how design engineering is pivotal in industries like automotive, aerospace, and manufacturing. The session also explored the role of simulation software and automation in driving efficiency and creativity in design.

Technical Talk on “New Innovations in Automation, Robotics and Advanced Manufacturing Methods”

Department of Mechanical Engineering, ATMECE in collaboration with Institutions Innovation Council – ATMECE has organised a Technical Talk on “New Innovations in Automation, Robotics and Advanced Manufacturing Methods” for the students of the Mechanical Engineering department on 18th December 2024. The Resource Person Mr. Srinivas Bhat, Head of the Center of Excellence (CoE) at GT&TC, Mysuru, who is an expert in the field of automation and advanced manufacturing technologies.

The talk provided an in-depth overview of the latest advancements in automation, robotics, and manufacturing methods, highlighting their transformative impact on various industries. Mr. Bhat emphasized how automation and robotics are streamlining production processes, reducing human error, and increasing operational efficiency. He also discussed the role of advanced manufacturing techniques such as 3D printing, AI-driven automation, and smart factories in shaping the future of manufacturing. y for multi-zone applications in commercial buildings.

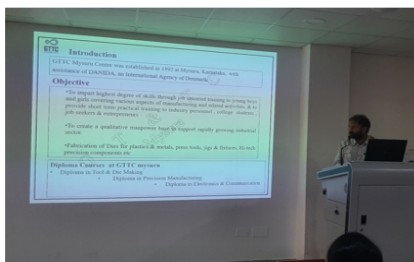

Technical Talk on “Innovative Approaches to HVAC, PLC, and SCADA Systems for Next-Gen Entrepreneurs”

Department of Mechanical Engineering, ATMECE in collaboration with Institutions Innovation Council – ATMECE has organized a technical talk on “Innovative Approaches to HVAC, PLC and SCADA Systems for Next-Gen Entrepreneurs” for the students of the Mechanical Engineering Department on 18th December 2024.

Mr. Chandrashekar P, Senior Engineer in Electrical division, KGTTI, Mysuru expressed the importance of HVAC systems. These systems are integrating IoT (Internet of Things) sensors, enabling real-time monitoring, predictive maintenance, and energy optimization. AI algorithms analyse data to optimize performance, ensuring systems adjust based on actual usage and environmental conditions. Innovative Smart thermostats and automated controls enhance user comfort while reducing energy consumption. Additionally, geothermal and renewable energy systems are gaining traction, providing eco-friendly heating and cooling solutions. Variable Refrigerant Flow (VRF) systems are also increasingly used, offering precise temperature control and energy efficiency for multi-zone applications in commercial buildings.



Faculty Achievements



Dr. Mohanakumara K C

Board of Examiner (Mechanical Engineering), VTU Belagavi.



Dr. Chetana S

Awarded a Research Incentive of Rs. 48000/- in recognition of his contributions to academic research and excellence.

Faulty publication in National and International Journals/Conferences			
SI. NO	Title of the Paper	Authors	Journal/Conference Name
1	Tribioelectrochemical Corrosion Behavior of the CNT–Aluminum 7039 Composite	Srinivasa K,Chetana S,Guddappa Halligudra, and Pavitra J	Journal of The Electrochemical Society
2	Synthesis of the novel coumarin probes and sensitive detection and separation of cations using HPLC and theoretical investigations	S. Chetana , Nashwan H. Ali , Maadh T. Abdulrahman , Seemaa H. Ahmed , M. S. Patel , H. Panwar ,.	Rasayan journal of chemistry
3	Optimized Graphene Oxide Content for Enhancement in the Mechanical Properties of Epoxy Composites	Hemanth, B.R. , Kattimani, M.A., Nadeem, M.M., Ahamed, M.B., Shariff, M.M., Rajan, V., Karthik, S.B., Rajesh, A. and Prasad, C.D.,	Journal of the Institution of Engineers India Series D
4	Catalytic behaviour of iron-based nanomaterials for the remediation of hazardous chemicals from wastewater: A Review	Guddappa Halligudra , Chetana Sabbanahalli Seema Singh , Priyavart Choudhary, Madhusudhana R , Girish Tigari , Shantharaja , Shang-Lien Lo	Journal of Physics and Chemistry of Solids
5	Machine Learning Based Surface Finish Prediction and Optimization of Process Parameters in Pulsed CO2 Laser Cutting of Particle (TiC) Reinforced Al6061 Composite Using KNN & ANN	S. Chethan M. Arunadevi, S. Saravanan, G. Mahesh	Journal of The Institution of Engineers (India): Series D

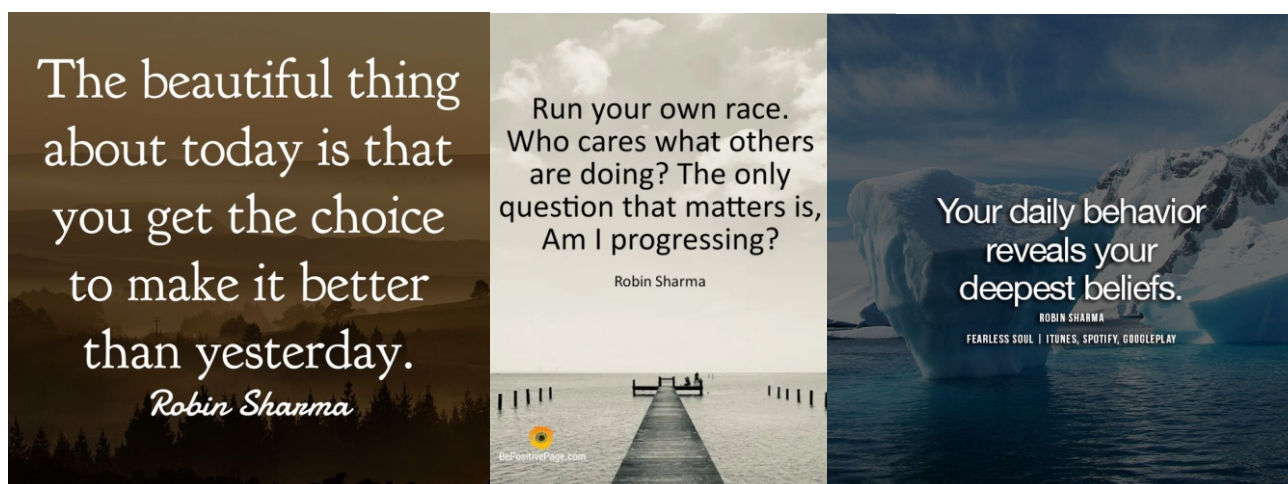

STUDENT PLACEMENT



ABHISHEK R L



AZGAR ALI Z



LIKHITH A P



MANOJ N

Company Name:
CLEANFIX-SCHEVARAN
SYSTEMS PVT. LTD.



**MOHAMMED
AMEEMIL IHSAN S**



**MOHAMMED
URUJ**



**SHARATH
KUMAR C**

ACADEMIC TOPPERS

II Year



RAJU S R
SGPA-8.20



DARSHAN H B
SGPA-7.95

III Year



AKSHAY H B
SGPA-8.32



DARSHAN R
SGPA-8.00

IV Year



LIKHITH A P
CGPA-7.49



ABHISHEK R L
CGPA-7.12



DEPARTMENT OF LIBRARY AND INFORMATION CENTER

Library and Information Center

A library is a collection of materials, books or media that are accessible for use. A library provides physical (hard copies) or digital access (soft copies) materials, and may be a physical location or a virtual space, or both.

Information and communication technology has revolutionized every walk of human society. Academic libraries have a brief history, beginning with chained and locked access libraries of past times to the present day hybrid, digital and virtual libraries that use the latest technology for provision of information through various services. Nowadays these libraries are surrounded by networked data that is connected to huge ocean of the internet based services to make desired information sources accessible to the academic community students and the faculty alike.

Electronic resources have given us the power to get information timely and manage information more effectively and also the means to dissolve barriers and offer equity of access to knowledge and information. These can be used for efficient retrieval and meeting towards electronic resources and services, which are found to be less expensive and more useful for easy access.

The academic system largely relies on teaching, learning and research. Eternally, education depends on information resources. These resources are the driving forces and factors for making a society an educated one. The educated society can exist only when information is stored, shared and utilized properly. In an academic arrangement, both 'education' and 'library' are inseparable – indivisible concepts, working for the promotion and evolution of teaching, learning and research for greater use of academia.

Access to E-resources is a service to help library users find E-Databases, E-Journals, E-Magazines-Books/E-Audio/E-Images, Data/GIS, Digital Library Projects, Electronic Exhibitions, and E-Subject Guide. Most e-resources come equipped with powerful search and retrieval tools that allow users to perform literature searches more effectively and efficiently.

ATMECE Library registered in NDLI and providing services.

The National Digital Library of India (NDLI) is an all-digital library that stores information (metadata) about different types of digital contents including books, articles, videos, audios, thesis and other educational materials relevant for users from varying educational levels and capabilities. It provides a single-window search facility so that learners can retrieve the right resources with the least effort in minimum time. NDLI is designed to hold content of any language and provide interface support for the leading vernacular languages. It is available on all popular forms of access devices including mobile apps on Android and iOS platforms. NDLI has been designed to benefit all kinds of users like students (of all levels), teachers, researchers, librarians, library users, professionals, differently abled users and all other lifelong learners. NDLI will provide a single window search facility to act as a one-stop shop for all digital educational resources. Information can be personalized based on the education level, choice of language, difficulty level, media of content and such other factors while other Digital libraries may not include all these choices. NDLI provides interface support for the leading vernacular languages and thus one can select the language of his/her choice to search or browse through NDLI. In other words, it is like a 'customized service' provided in a 24x7 integrated environment to suit a user's.



Number of collections available in Library		
Departments	Titles	Volumes
Department of Computer Science and Allied Branches	2077	8942
Department of Mechanical Engineering	648	3543
Department of Electronics & Communication	771	3775
Department of Electrical & Electronics	620	3099
Mdepartment of Civil Engineering	491	2010
Post Graduate Depts.	389	1037
DVD/CDs		1782
Journals & Magazines		78

DEPARTMENT OF PHYSICAL EDUCATION AND SPORTS

Department of Physical Education and Sports

“ATMECE's mission is to foster a strong “culture of fitness” among students, faculty, and staff.”

ATME College of Engineering continues to champion a vibrant “culture of fitness” among students, faculty, and staff, firmly believing that physical activity is a cornerstone of holistic education. Beyond its physical benefits, regular participation in sports has been proven to enhance memory, sharpen cognitive skills, and promote overall mental well-being. With a mission to nurture physical education leaders of high academic and athletic caliber-rooted in the harmony of body, mind, and spirit-we strive to create well-rounded individuals committed to personal excellence and service to society.

It gives me great pleasure to present the Annual Sports Report for the year 2024–2025. Our students have brought pride to the institution by actively participating and achieving commendable success in various sports and games organized by VTU, the University of Mysore, and several other open tournaments. The college took part in a range of competitions including VTU and Mysuru City inter-collegiate tournaments, JSS Science and Technology University events, Mysuru Dasara district, division, and state-level championships.

Our college teams actively took part in various sports and games such as Cricket, Throwball, Football, Basketball, Baseball, Handball, Softball, Athletics, Table Tennis, Chess, Volleyball, Wrestling, Hockey, Kabaddi, Best Physique, Weightlifting, and Powerlifting, as well as cultural events like the Youth Festival. Across every field, court, and arena, our athletes played with passion, discipline, and a true spirit of sportsmanship—bringing laurels to the institution and upholding the ATME spirit of excellence.

Sports Achievement for the Academic Year 2024-25

- **VTU was entrusted us to host the VTU Intercollegiate State Level Baseball (M&W) Championship 2025-26 and VTU team selection trials from 29-31 May, 2025.**
- **VTU was entrusted us to host the VTU Intercollegiate Mysuru Division Men Volleyball Championship 2025-26 on 21st April 2025.**
- **VTU was entrusted us to host the VTU Intercollegiate Mysuru Division Men Tug of War Championship 2024-25 on 07th December 2024.**
- **VTU was entrusted us to host the VTU Intercollegiate Mysuru Division Women Throwball Championship 2024-25 on 07th December 2024.**
- **ATMECE Softball Men's team emerged as a Champion's of VTU Inter Collegiate Rest of Bengaluru and State Level Softball Championship 2024-25, organized by SJMIT, Chitradurga at its college grounds from 11-12, Nov 2024.**
- **ATMECE Softball Women's team emerged as a Champion's of MCICT Inter Collegiate Softball Championship 2024-25, organized by SBRR Mahajan FGC, Mysuru at its college campus on November 25-26, 2024.**
- **ATMECE Softball Men's team emerged as a Champion's of MCICT Inter Collegiate Softball Championship 2024-25, organized by SBRR Mahajan FGC, Mysuru at its college campus on November 25-26, 2024.**
- **Mr. Vikyath K V of 3rd year EE dept. won the Gold medal (70kg Category) in VTU Intercollegiate State Level Wrestling championship 2024-25 held on 15-16, November 2024 at GAT, Bengaluru.**
- **ATMECE Cricket Men's team secured Runner-Up in the VTU inter collegiate Mysuru Division Cricket Tournament 2024-25 organized by NIE, Mysuru at its college campus from 20th March to 1st April 2025.**
- **ATMECE Table Tennis Women's Team secured Runner's-Up in the VTU Inter Collegiate Mysuru Division Table Tennis Championship 2024-25, organized by VVCE, Mysuru, at its college campus on 16th July 2024.**

- ATMECE Softball Women's team secured 2nd Runner's-Up in the VTU State Level Inter Collegiate Softball Championship 2024-25 organized by SJMIT, Chitradurga at its college grounds from 09-10, Nov 2024.
- ATMECE Softball Men's team secured 2nd Runner's-Up in the VTU State Level Inter Collegiate Softball Championship 2024-25 organized by SJMIT, Chitradurga at its college grounds from 13-14, Nov 2024.
- Mr. Vikyath K V of 5th Sem EEE Department secured **Bronze Medal** in the MCICT Inter Collegiate Men Wrestling Championship (70+ kg Category) for the year 2024-25 organized by SBRR Mahajana First Grade College, Mysuru on 18, October 2024 @ Sports Pavilion, Mysuru.
- Mr. Dhiraj Rao R of 1st sem CSE student won the **Gold Medal** [-67 kg Category] in Point Fight at MCICT Inter Collegiate Men Kick Boxing Championship 2024-25 organized by UOM, Mysuru on 15th October 2025 at Yuvaraja's College, Mysuru.
- Mr. Mohith Krishna K of 1st sem CSE- Cyber Security student secured **Silver Medal** [-52 kg Category] in Kick Light at MCICT Inter Collegiate Men Kick Boxing Championship 2024-25 organized by UOM, Mysuru on 15th October 2025 at Yuvaraja's College, Mysuru.
- Ms. Tasbiya Taskin of 3rd sem CS- Design student secured **Bronze Medal** [-45 kg Category] in Point Fight at MCICT Inter Collegiate Women Kick Boxing Championship 2024-25 organized by UOM, Mysuru on 15th October 2025 at Yuvaraja's College, Mysuru.
- Mr. Lokesh S of 7th sem CSE student won the **Gold Medal** [-55 kg Category] in MCICT Inter Collegiate Men Karate Championship 2024-25 organized by UOM, Mysuru on 14th October 2025 at Yuvaraja's College, Mysuru.
- Mr. Nikhila Kumara M M of 7th sem AIML student won the **Gold Medal** [-84 kg Category] in MCICT Inter Collegiate Men Karate Championship 2024-25 organized by UOM, Mysuru on 14th October 2025 at Yuvaraja's College, Mysuru.
- Mr. Samuel A of 1st sem CS- Data Science student won the **Gold Medal** [-67 kg Category] in MCICT Inter Collegiate Men Karate Championship 2024-25 organized by UOM, Mysuru on 14th October 2025 at Yuvaraja's College, Mysuru.
- Mr. Dhiraj Rao R of 1st sem CSE student secured the **Bronze Medal** [-60 kg Category] in MCICT Inter Collegiate Men Karate Championship 2024-25 organized by UOM, Mysuru on 14th October 2025 at Yuvaraja's College, Mysuru.
- Ms. Tasbiya Taskin of 3rd sem CS- Design student secured **Bronze Medal** [-45 kg Category] in MCICT Inter Collegiate Women Karate Championship 2024-25 organized by UOM, Mysuru on 14th October 2025 at Yuvaraja's College, Mysuru.

University Representation

Sl. No	Name of the Student	Year / Branch	Game	Remarks
01	Vikyath K V	3 rd yr. EE	Wrestling	Second Time
02	Ananth Kumar V	4 th yr. CS	Softball	Third Time
03	Shivshankar B Naik	3 rd yr. CS	Softball	Second Time
04	Harish Kumar G	3 rd yr. EE	Softball	First Time
05	Prakruthi K	3 rd yr. CD	Softball	Second Time
06	Ankitha A P	1 st yr. EE	Softball	First Time
07	Bhuvan S	4 th yr. CS	Baseball	Second Time
08	Adithya K L	4 th yr. CS	Baseball	Second Time
09	Kushal U	4 th yr. EC	Wushu	Second Time
10	Nithin M Singh	4 th yr. CS	Football	First Time
11	Nisarga B R	2 nd yr. EC	Baseball	First Time
12	Swathi K S	2 nd yr. CS	Baseball	First Time
13	Ananth Kumar V	4 th yr. CS	Baseball	First Time

Sports Staff

Sl. No	Name	Designation	Email
1	Dr. Muralidhar M P	Director of Physical Education	mpmuralidhar7@gmail.com
2	Mr. Manjunatha	Grounds men	-

Report on Women Cell

Women cell mainly focuses on Women's empowerment that promotes women's sense of self-worth, their ability to determine their own choices, and their right to influence social change for themselves and others. Women cell conducts activities throughout the year and gives a platform for the stakeholders to exhibit their talents. Women cell recognizes and honors the women achievers working in different fields.

Objective of the Women Cell is to Empower women by Encouraging strong network among members; Providing opportunities for women to share knowledge and exhibit talents; recognizing women achievers. Women Cell is actively conducting the events and outreach programs from 2015-16. It has MOM with Aspire for Her and received certificate of Appreciation for the year 2022-23.

In the AY 2024-25 Women Cell in association with Mahaganapathy Seva trust and Inner Wheel Club conducted Free Cancer detection camp on 28, 29 .08.2024. On 12.09.2024 Women Cell in association with ARDSI taken part in Trekking to Chamundi hill





From 12.09.2024 to 22.02.2025 the Dr.Bhagyashree S R, Chairpeson Women Cell of ATME College Of Engineering in association with Inner Whell Club, Mysuru convened programmes at **different schools in and around Mysuru** on Sustainability and E-waste management.

Women's Cell, ATMECE in Association with Inner wheel club, Mysuru conducted a student outreach program on February 28, 2025 on **“Adverse Effect of Smartphones on Health and Earth”**.



ATME College of Engineering organized a series of events towards the celebration of International Women's Day for Girl students and Teaching and Non-Teaching members of the Institution. "International Women's Day" was organized by Women's Cell, CICC in association with AFH, Mumbai on Wednesday, 12th March 2025 at ATME College of Engineering, Mysuru



As a part of Induction Program in association with Women's cell and CICC of ATME College of engineering has organized a Workshop on "SELF DEFENCE THROUGH MARTIAL ARTS" on 17-03-2025 at 2:00 Pm in Civil Auditorium at ATME College of engineering. The workshop was conducted for first year students. **Bharathi Anand**, Chairman of Women's Sports Commission, Akila Karnataka Sports Karate Association (AKSKA), Mysore was the guest for the workshop.



On 14.06.2025 Women Cell in association with NSS has involved in activity conducted by CII Mysuru on Beat Plastic Pollution and Awareness Session.



On 23.06.2025 Women Cell in association with Office of Dean Student Affairs conducted a program on Mindfulness for the Well-Being



The Little Walk

One quiet evening, just as the sun began to set, I noticed a tiny ant walking across a leaf. Nothing grand, nothing dramatic - just a small creature going about its day.

But something about that moment felt different.

The light was soft and golden, wrapping everything in a warm glow. And there it was - this little ant, its antenna catching the sunlight like fine threads of gold. For a second, it didn't feel like I was watching just an insect anymore, it was a character in its own silent narrative.

I lifted my phone to capture it - no fancy gear, just a simple lens and a quiet feeling that this moment mattered.

That ant wasn't hurried. It wasn't lost. It knew where it was going. And even though no one else might notice its journey, it kept moving - steady, quiet, determined.

Framing the shot, I found myself smiling.

Because in its tiny steps, I saw the reflection of resilience, the courage to keep going, even when the world isn't watching.

Somehow, that reminded me a lot of us—how each of us in our own silent battles and pursuits, simply strives to move ahead in our own little ways and at a pace only we understand. And the gentle truth that the simplest moments can hold the brightest light - if only we pause long enough to notice.



By: Ms. Amulya G
II Semester MBA
Department of MBA
ATME College of Engineering
Mysuru

The Cybernetic Revolution: Merging Man and Machine

By Syeda Ayesha

In a world where technology evolves at an unprecedented pace, we find ourselves on the brink of a new era: the Cybernetic Revolution. This thrilling movement is reshaping our understanding of what it means to be human, as engineers and scientists work tirelessly to develop advanced cybernetic enhancements that blur the lines between man and machine.

The Rise of Cybernetics:

The journey into cybernetics began with a simple yet profound goal: to enhance human capabilities. Engineers have pioneered sophisticated prosthetics that not only restore lost functions but also surpass the natural abilities of the human body. Imagine a future where individuals with cybernetic limbs can lift weights beyond human limits or where the visually impaired can regain sight through neural implants that interface directly with the brain.

Cutting-Edge Technology:

At the core of these advancements lies a fusion of groundbreaking technologies, including artificial intelligence, nanotechnology, and biotechnology. Engineers are creating neural interfaces that facilitate seamless communication between the human brain and machines. This innovation allows users to control devices with their thoughts, unlocking a world of possibilities for both everyday tasks and complex operations.

Consider the potential of a cybernetic eye equipped with AI, enhancing vision with real-time data overlays and instant language translation. Meanwhile, exoskeleton suits are being designed to assist those with mobility impairments, enabling them to walk and run with newfound strength and agility.

Navigating Ethical Dilemmas:

As with any revolutionary technology, the rise of cybernetic enhancements brings forth significant ethical dilemmas. Questions about identity, privacy, and inequality loom large. Will those who can afford these enhancements gain an unfair advantage? What happens to our humanity when physical and cognitive abilities can be augmented at will?

Engineers and ethicists are collaborating to address these concerns, advocating for regulations that ensure equitable access to cybernetic technologies. They stress the importance of maintaining human dignity and autonomy in a world where enhancements become commonplace.

A Glimpse into the Future:

As the Cybernetic Revolution unfolds, society must grapple with the implications of merging man and machine. Will we embrace a future where human limitations are a relic of the past, or will we proceed with caution, mindful of the ethical boundaries that define our humanity?

In this brave new world, engineers play a pivotal role not only in technological development but also in shaping the narrative of what it means to be human. As they push the boundaries of innovation, they invite us to ponder a profound question: In our quest for enhancement, what do we risk losing?

Conclusion:

The Cybernetic Revolution is more than just a technological advancement; it is a philosophical exploration of identity, capability, and the essence of being human. As we stand on the precipice of this new era, the collaboration between engineers, ethicists, and society will determine the path we take. The future is not solely about merging man and machine; it is about understanding the very nature of humanity itself.

How a Tiny Chip Powers Your Life – A Deep Dive in Simple Words

From Silicon to Smartphones: The Incredible Journey of a Tinychip

From unlocking your phone to enabling smartwatches and self-driving cars, microchips are the invisible engines powering our digital world. Yet, few realize the complexity and collaboration involved in building these miniature marvels. This article demystifies the lifecycle of a chip — from its initial design to integration inside the gadgets we use daily.

1. What Is a Chip?

At its core, a chip — also called a microchip or integrated circuit (IC) — is a tiny piece of silicon that performs computations and decisions at incredible speeds.

It can:

- **Calculate:** Perform millions of math operations every second.
- **Control:** Make logical decisions like "If temperature > 40°C, turn on the fan".
- **Communicate:** Transfer data between a camera and a display in real-time.

Although it doesn't "think" like humans, it follows instructions encoded in logic with lightning precision.

2. Designing the Chip: Architecting the Invisible

Before a chip is physically built, engineers design it using Hardware Description Languages (HDLs) like Verilog or SystemVerilog. These are similar to programming languages but tailored for describing hardware behavior. This digital design phase includes:

- **Defining functions:** What the chip should do — arithmetic, signal processing, image capture, etc.

- **Setting constraints:** Speed, power usage, and size.
- **Describing architecture:** Laying out logic blocks, pathways, memory, and processing units.

Did you know? A modern chip can hold over 10 billion transistors, each acting as a tiny on/off switch — all defined through lines of code.

3. Verification: The Digital Proving Ground

Before fabrication, chips must undergo design verification — a virtual test environment that ensures correctness, reliability, and robustness. This is done using:

- **UVM (Universal Verification Methodology):** A framework for building flexible, reusable test environments.
- **Simulators (e.g., QuestaSim, VCS):** Tools that run millions of test scenarios.
- **Assertions and Coverage Metrics:** Techniques to catch unexpected or incorrect behaviors.

Think of it like crash-testing a car — except virtually. Chips are stressed with edge cases and rare conditions to ensure they never fail in real-world usage.

4. Physical Design: Mapping the Silicon City

Once verified, the chip's logic needs to be translated into physical layout — this is the backend phase.

Key steps include:

- **Placement:** Positioning transistors, gates, and blocks on silicon.
- **Routing:** Connecting components with microscopic wires, like city roads.
- **Optimization for PPA (Power, Performance, Area):** Ensuring speed, efficiency, and minimal footprint.
- **Timing analysis:** Verifying signal synchronization.
- **Thermal and noise analysis:** Preventing overheating and interference.

This stage uses tools like:

- **Cadence Innovus**
- **Synopsys ICC2**
- **Mentor Calibre** (for physical rule checks)

Imagine building an entire city — traffic systems, power lines, plumbing — all on an area smaller than your fingernail, with no room for error.

5. Fabrication: Printing Circuits with Light

Once layout is finalized, the design is sent to a semiconductor fabrication plant or fab (e.g., TSMC, Intel, Samsung).

Here, the chip is created through a process called photolithography, which uses ultraviolet light to etch patterns onto a silicon wafer.

Fabrication involves over 1,000 precision steps, such as:

- **Etching and doping:** Modifying materials to control electrical behavior.
- **Layering metals:** Building interconnects across chip layers.
- **Cleaning and inspecting:** Ensuring zero dust particles - clean rooms are 1000x cleaner than surgical theaters!

Chip features are etched at 5 nanometers - roughly 1/20,000 the width of a human hair.

6. Testing, Dicing, and Packaging

Once the wafer is processed:

1. Initial Testing: Each chip is electronically tested.

2. Dicing: The wafer is cut into individual chips.

3. Packaging: Chips are enclosed in protective materials (the black square with silver pins you see).

4. Final Testing: Ensures durability under varying heat and pressure.

Only the chips that pass all stages move forward to customers.

7. Integration: Embedding the Brain

Now ready, the chip is integrated into larger electronic systems:

- **Smartphones**
- **Laptops and servers**
- **Electric vehicles**
- **IoT and wearable devices**

They are mounted onto PCBs (Printed Circuit Boards) along with memory, power supplies, and other components — bringing entire products to life.

8. A Global Symphony of Engineering

The journey of a chip is a marvel of international collaboration:

- **Design in India or the U.S.**
- **Verification in Europe or Israel**
- **Fabrication in Taiwan or South Korea**
- **Testing and packaging in China or Malaysia**
- **Integration by global tech brands**

All this — to make our phones faster, our cars smarter, and our lives more connected.

Final Thoughts

The next time you swipe your phone, stream a video, or navigate with GPS, remember: behind every digital moment lies a silent symphony of engineering, code, physics, and innovation - all packed inside a chip smaller than your fingernail.

The microchip is not just a component - it's the modern world's brain and heartbeat.

Mr. Chandra Shekar P
Assitant Professor
Department of ECE
ATMECE, Mysuru

A TOM AND JERRY CARTOON TALES

Travel back in time to your early years. Tom and Jerry's 78+ years together: The evolution of this game of cat and mouse throughout time. our affection for Tom and Jerry is still alive. Watching the comedic cartoon series Tom and Jerry's Show is more of a habit. Although they were great friends, they also ran after each other for their lives. Watching Tom and Jerry's hide-and-seek game is always exciting and a lot of fun. The secret to remaining wise and happy is to laugh and shake off the blues. Cartoons are a great way to lighten the mood and strengthen bonds with others. Consider this more carefully. The Tom and Jerry cartoons convey a message that teaches valuable lessons like:

1. We argue more with those we care about:

Tom and Jerry are still battling. In the end, they are excellent friends, regardless of the size of their arguments—from minor ones in which Tom would pursue Jerry for waking him up to more serious ones in which Tom got into trouble due to the mouse. Therefore, remember the value of friendship and forgive and go on.

2. Have faith in Love and trust:

They have been the foundation of Tom and Jerry's friendship. Despite their naughty and rude behavior, they trusted one another, which is why they played hide-and-seek. The person you trust the most is the target of the best practical jokes. Trusting your loved ones is the lesson we learn, and if your friend is genuine, you will either be blessed with a treasured friend or maybe learn some wonderful things.

3. The secret to friendship is confidence:

In every episode, Jerry exudes confidence. When he is being pursued, he runs like a deer and timidly hides in a safe place. Tip-toed, he plays thenaughty and turns to a large cat. Therefore, having confidence makes it easier to succeed in these challenging situations.

4. Does size matter?

Absolutely not! Remember that tiny has a lot of power. Despite his small size, Jerry was bold and prepared to take on the strong Tom. There is a lesson to be learned from Jerry outwitting Tom: Be cool, collected, and clever. Even the strong can crumble.

5. The spirit of teamwork:

Tom and Jerry have always fought, but as we can see, they frequently come together to form a powerful team when they are up against a shared foe. As the adage says, "United we Stand, divided we fall," Tom and Jerry also impart compassion and collaboration to us.

6. Take lessons from errors:

Tom never caught Jerry using the same methods. If he didn't succeed, he would try a different tactic the next time to catch Jerry. "I came to know about 999 ways that won't work," as Thomas Edison once remarked. Therefore, while making mistakes is inevitable in life, doing it repeatedly is stupid. Thus, take lessons from your errors.

7. Caring and sharing:

Although Tom and Jerry were bitter rivals, they also had similar feelings. They always attempted to keep the other person happy because none of them could watch the other person unhappy. It teaches us to take care of one another! You will be happy because it will make the other person happy.

8. Friendship for life:

One of the most priceless and cherished gifts is friendship. In good times and bad, Tom and Jerry remained together forever. Appreciate the significance of relationships in your life if you remember the song, "In good times, in bad times, I'll be there for you forever." They have great significance.

9. Good things come to those who give them:

According to the proverb, "What goes around, comes around," Despite his best efforts, Tom fails to carry out his cunning plans for Jerry. Therefore, believe in karma and act morally. Expectations can be painful.

10. Life presents obstacles:

Jerry and Tom are quite active. Both encounter obstacles in their own unique ways and manage to get past them. We learn that no matter what, you should always confront life's obstacles as you constantly deal with issues you never anticipated. Everyone rises and falls. There is a way, so don't worry about it; sometimes it will work and other times it won't.

Tom and Jerry is more than entertainment, it's a philosophical playground. Its themes—perseverance, the duality of rivalry/friendship, and resilience—resonate across ages. As the cartoon's chase continues, so does its relevance, reminding us that life's struggles, like Tom's schemes, are best met with creativity and humor.

This article synthesizes the franchise's history with its deeper life lessons, showcasing why Tom and Jerry remains a timeless allegory for the human experience.

Written by, LIKITHA M
(4AD22EE029)
EEE, 6th Sem, ATMECE

The Forgotten Genius - Sir Nikola Tesla

He was born in a poor family, Yet he died poor with no family. There were a lot of peaks and valleys in his life trip But were they all worth it? He was born with intelligence. But was he successful during his last breath? He had his siblings in his childhood But only a pigeon was his friend. In the end He is one of the reasons for current technology. But did he really get all the deserved glory? Success comes to those who wait, he said. But where is the success he deserved or didn't he wait?

Once, when a reporter asked Albert Einstein how it feels to be the most intelligent person in the world, Einstein replied "I don't know, you'll have to ask Nikola Tesla". That's the legacy Sir Nikola Tesla has left behind. On July 10, 1856 in Croatia a child was born during a lightning storm. When the nurse saw the child, she said that this child will be the child of darkness. Hearing this, the mother replied "No, he will be the child of light". The child was none other than Nikola Tesla. Well, his mother was right but the nurse was not wrong either. Though he was a man of light, his life was full of darkness.

He is one of the main reasons for today's electrical technologies and development but he was not remembered or given credit for his inventions. He had a great memory which was an inherited trait from his mother. His mother had Eidetic memory, she was able to remember photos and also different poems perfectly.

Tesla was able to finish his studies easily with the help of this ability. Once, when he was out horse riding with his brother, his brother accidentally fell from the horse and lost his life.

After this event, Nikola got cholera and was in its last stage. Doctors had left their trials and God was their only hope. Tesla's father, who was a priest, felt very sad that he would lose another child of his. Nikola, looking at his sad father, requests to pursue engineering. His father agrees to his request, saying "if this can cure your disease, then of course you can pursue engineering".

Listening to this, Tesla feels happy and he gets cured in a few days. Further he continues engineering and after some years he drops out from his college for some reason.

In January 1879, Thomas Alva Edison invented the "bulb". But the challenge was to supply electricity in order to light those bulbs in every house. Edison mainly worked with direct current(DC), so after a few years he made facilities to supply direct current to every house. But the problem was that DC can't flow for more than 0.5 miles in distance. At the same Nikola at the age of 28, joins Edison's company. As Tesla was working on alternating current (AC), he brought this concept to Edison. But Edison denied his concept and told Tesla that, if he improves the working of DC, he would in turn pay him 50000 dollars which was a quite huge money at that time. Tesla agrees and improvises, the next day when he shows his works to Edison and asks for his money,

Edison tells that it was a joke, telling "Tesla, you don't understand our American humor." Listening to this Tesla resigns the job and thinks of opening his own company, where he can work on AC and establish it world wide as there were no limitations in it. This is when a huge war starts between the two of them, famously called "the war of the currents". Tesla convinces George Westinghouse who was a well known American entrepreneur. Then they start a new company called AC current which runs successfully. But Edison had his eyes on it and tried to stop Nikola and his company by spreading fake news. Telling that AC is very dangerous to people and he purposely killed many innocent animals to prove it too. Like this Edison tried different ways to stop him but Nikola was unstoppable.

Times passed and Tesla lost all his money as he was involved in many expensive and publically failed electrical projects, which was between 1920 and 1935. Tesla was also working on radio and X-ray which was stolen by Guglielmo Marconi and W C Roentgen and both of them won nobel prize for it. Poor Tesla went bankrupt and then got isolated in a hotel room. On January 7th, 1943 he was found dead lying on the bed. He spent his last 5 to 6 years talking with his only friend, which was a pigeon. Tesla mostly believed in research more than development, which was one of the reasons for Tesla's failure in life.

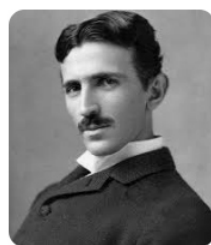

Radio over Fiber (RoF): An emerging technology in Optical Fiber Communication

Introduction:

In today's world of digital information, the demand for faster, more secure, and more reliable communication systems is ever-growing. Among the most revolutionary technologies enabling this digital transformation is Optical Fiber Communication

From high-speed internet to submarine communication cables, optical fibers have become the backbone of global telecommunications, offering unprecedented speed and bandwidth compared to traditional copper-based systems.

Radio over Fiber (RoF) is an advanced technology that merges the high bandwidth of optical fiber communication with the flexibility and mobility of radio frequency (RF) wireless systems. It involves modulating radio signals onto light waves and transmitting them through optical fibers. This combination is highly effective for applications like 5G networks, antenna remoting, and wireless backhaul.

Definition: Radio over Fiber (RoF) is a technology that transmits radio frequency (RF) signals over optical fiber links by modulating them onto light waves. It entails the use of optical fibre links to distribute RF signals from a central location (headend) to Remote Antenna Units (RAUs).

RoF makes it possible to centralize the RF signal processing functions in one shared location (headend), and then to use optical fiber, which offers low signal loss (0.3 dB/km for 1550 nm, and 0.5 dB/km for 1310 nm wavelengths) to distribute the RF signals to the RAUs, as shown in Figure 1

Figure 1: The Radio over Fibre System Concept

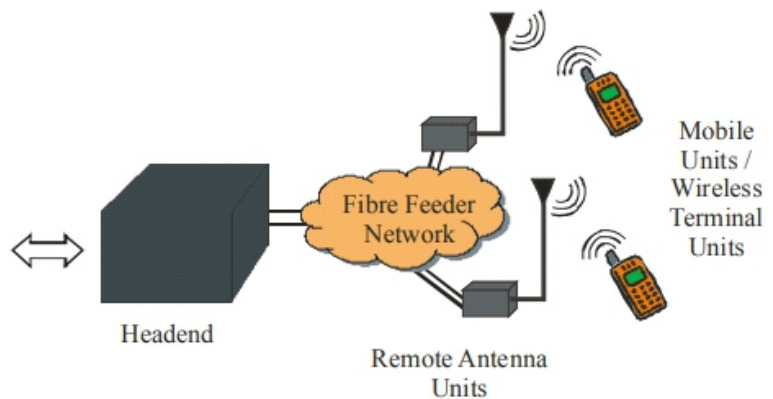

Techniques for Transporting RF Signals over Optical Fibre

There are several optical techniques for generating and transporting microwave signals over fibre. By considering the frequency of the RF signal fed into the RoF link at the headend in comparison with the signal generated at the RAU the RoF techniques may be classified into three categories –

- RF-over-fibre (RFoF),
- IFOver-Fibre (IFoF),
- Baseband-over-Fibre (BBoF).

RFoF involves the transmission of the actual RF signal over the fiber. However, in IFoF and BBoF the desired microwave signal is generated at the RAU through up-conversion with a LO, which is either provided separately at the RAU, or is transported remotely to the RAU.

RF Signal Generation by Intensity Modulation and Direct Detection

The simplest method for optically distributing RF signals is simply to directly modulate the intensity of the light source with the RF signal itself and then to use direct detection at the photodetector to recover the RF signal. This method falls under the IM-DD, as well as the RFoF categories. There are two ways of modulating the light source. One way is to let the RF signal directly modulate the laser diode's current. The second option is to operate the laser in continuous wave (CW) mode and then use an external modulator such as the Mach-Zehnder Modulator (MZM), to modulate the intensity of the light. The two options are shown in Figure 2. In both cases, the modulating signal is the actual RF signal to be distributed. The RF signal must be appropriately pre-modulated with data prior to transmission. Thus RFoF requires costly high-frequency electro-optic equipment at the headend.

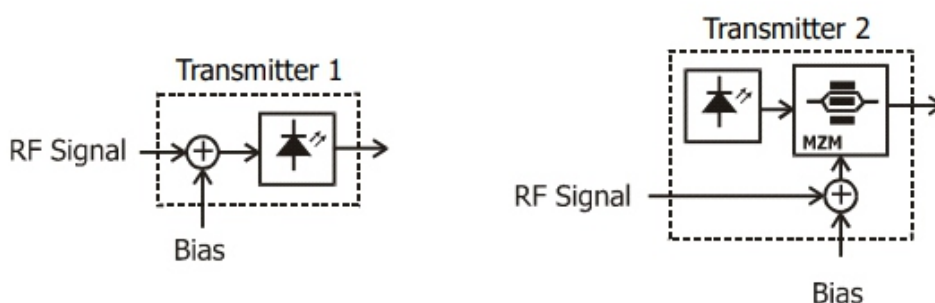

Figure 2: Generating RF Signals by Direct Intensity Modulation (a) of the Laser, (b) Using an External Modulator

After transmission through the fibre and direct detection on a photodiode, the photocurrent is a replica of the modulating RF signal applied either directly to the laser

or to the external modulator at the headend.

Advantages of IM-DD

- The advantage of this method is that it is simple.
- If low dispersion fibre is used together with a (linearised) external modulator, the system becomes linear
- These systems can be easily scaled to accommodate growing bandwidth demands and can be adapted to various network architectures

Applications of IM-DD

- RoF systems can connect the Mobile Telephone Switching Office (MTSO) to base stations (BS), providing a cost-effective solution for distributing RF signals over the network.
- RoF can address coverage gaps in areas like tunnels or mountainous regions.
- RoF can be integrated into HFC (Hybrid Fiber Coaxial) networks to improve signal distribution.

Mrs. Madhurya B Eshwar
Assitant Professor
Department of ECE
ATMECE, Mysuru



Yoga: More Than Just Exercise

Yoga is becoming more and more popular around the world. What exactly is it, where did it come from and what are the health benefits of doing yoga?

Do the preparation task first. Then read the article and do the exercises.

What is yoga?

Most people know yoga as a kind of exercise which aims at developing strength and flexibility. To practice yoga, you learn a series of 'postures',



where you put your body into different positions. Correct breathing is also important. However, yoga is about more than just exercise. In 2014, the Prime Minister of India, Narendra Modi, asked the United Nations to create an International Day of Yoga, saying that yoga 'is not about exercise but to discover the sense of oneness with yourself, the world and nature'. He felt that yoga could not just help people to be healthier but also help connect people to each other and to nature. The United Nations agreed, and International Yoga Day is now celebrated on 21 June.

Where did yoga come from?

The history of yoga goes back at least 5,000 years, and some people claim it is nearer than 10,000 years ago. It was first developed in Northern India and at this stage was a spiritual as well as a physical form of exercise, connected with both Hinduism and Buddhism. In the late 19th and early 20th centuries, yoga was introduced to the Western world when Swami Vivekananda travelled to the United States to talk about yoga at a conference in Chicago in 1893. Others followed in the 1920s and 1930s, and by the 1960s yoga had become a very

popular form of exercise in the United States and in Europe. Most people who practice yoga today do not do it for spiritual reasons.

What are the benefits of yoga?

Yoga is good for the mind and body. Regular practice of yoga helps people to improve their balance and stamina. Although you won't really get out of breath, like you might playing football or running, it does help to keep your heart healthy, and you can lose weight. It can also help with back pain. The breathing taught in yoga can help people to reduce stress and anxiety. There are lots of different possible breathing patterns you can do. Yoga also improves concentration and helps people to sleep better, so it's great for anyone who's under pressure at work or in their studies.

Kinds of yoga

There are lots of different kinds of yoga, so you can choose what suits you best. Hatha Yoga is often good for beginners, because you hold each position for a few breaths. In Vinyasa Yoga you change position much more quickly and you might get out of breath. It's quite challenging if you haven't done much yoga before. Bikram Yoga is sometimes called 'hot yoga', because the room must be heated to around 40 degrees. As well as these and other more traditional forms of yoga, there are also some more unusual modern forms of yoga. For example, you might enjoy 'laughter yoga', where people do breathing exercises and laugh about nothing in particular – laughing is very good for your health. Or what about 'Aeroyoga', where you do yoga while you are hanging from the ceiling? It's supposed to be very good for your back. Or 'Doga', where you do yoga together with your pet dog?

Whatever kind of yoga you choose, there are definitely some health benefits, and you should have fun too.

By: Mr. Solin James

II Semester MBA

Department of MBA

ATME College of Engineering, Mysuru

Virtual Reality: A Gateway to Immersive Digital Experiences

Introduction:

In the ever-evolving landscape of digital technology, Virtual Reality (VR) has emerged as a ground breaking innovation that is transforming the way we experience the world. From gaming and education to healthcare and scientific research, VR is redefining the boundaries between the physical and digital realms. As this immersive technology becomes more accessible, it invites a deeper understanding of its capabilities, applications, and challenges. This article explores the fundamentals of VR, its real-world applications, potential drawbacks like VR sickness, and the vast scope it holds for the future.

Definition of Virtual Reality:

Virtual Reality is a simulated experience that immerses the user in a computer-generated environment. It is defined as:

"Inducing targeted behavior in an organism through artificial sensory stimulation, while the organism remains mostly unaware of the interference."

This means the user interacts with a digitally crafted environment through sensory inputs such as sight and sound, often using devices like VR headsets, gloves, and motion controllers. The goal is to create a convincing and seamless experience that makes users feel as though they are truly present in a different place or situation.

Four key components appear in the definition:

1. Targeted behaviour: The organism is having an "experience" that was designed by the creator. Examples include flying, walking, exploring, watching a movie, and socializing with other organisms.

2. Organism: This could be you, someone else, or even another life form such as a fruit fly, cockroach, fish, rodent, or monkey.

3. Artificial sensory stimulation: Through the power of engineering, one or more senses of the organism become co-opted, at least partly, and their ordinary inputs are replaced or enhanced by artificial stimulation.

4. Awareness: While having the experience, the organism seems unaware of the interference, thereby being "fooled" into feeling present in a virtual world. This unawareness leads to a sense of presence in an altered or alternative world. It is accepted as being natural.

Modern VR Experiences

The modern rise of VR has been propelled by technological breakthroughs in smartphones, which provided affordable components for displays, sensors, and processors. This democratization is similar to the personal computer and web revolutions, leading to a vast range of new applications and experiences.



The versatility of VR technology has led to its adoption across various sectors:

- **Gaming and Entertainment**

Perhaps the most well-known application, VR has revolutionized gaming by offering players a fully immersive and interactive environment. Games are no longer just viewed -they are experienced from within.

- **Education and Training**

VR offers students and professionals a safe and realistic platform to learn. Medical students can practice surgeries, engineering students can simulate machinery operations, and pilots can train using flight simulators.

- **Healthcare**

In therapy and rehabilitation, VR is used to treat conditions such as PTSD, phobias, and motor skill disorders. It also aids in pain management and mindfulness-based therapies.

- **Architecture and Design**

Architects and designers can walk clients through virtual models of buildings or products before they are physically constructed, allowing for efficient design reviews and modifications.

- **Virtual Tourism**

With VR, users can explore historical landmarks, distant cities, or even the surface of Mars, all from the comfort of their homes.

- **Social Interaction**

VR platforms are enabling new forms of social interaction through virtual societies and metaverses, where people can meet, collaborate, and socialize in shared digital spaces.

VR Sickness

Despite its benefits, VR is not without challenges. One of the most common issues is VR sickness, also known as cyber sickness. This condition occurs when there is a mismatch between what the user sees in the virtual environment and what their body feels. Symptoms may include:

- **Nausea**
- **Dizziness**
- **Headaches**
- **Eye strain**

VR sickness is similar to motion sickness and is often caused by latency, frame rate issues, or prolonged use. To minimize its impact, developers must design experiences with smooth motion, appropriate frame rates, and user-centered controls.

Conclusion

Virtual Reality stands as one of the most transformative technologies of the 21st century. It is reshaping how we learn, heal, design, play, and connect. While it presents certain challenges such as VR sickness and technological limitations, ongoing research and innovation are steadily overcoming these hurdles. As VR continues to mature, it holds the promise of bridging imagination with reality—offering not just new ways to see the world, but entirely new worlds to experience.

By:
Guruprasad K N
Assistant Professor
Dept. of ECE
ATMECE



Sudha Murthy

Sudha Murthy born on 19 August 1950, Shiggaon, Karnataka is an Indian engineer turned philanthropist widely known as founder chairperson of Infosys foundation and spouse of Infosys co-founder N.R.Narayana murthy.

She is the first female engineer hired by TELCO and also worked as senior systems analyst at Walchand Group before marrying Narayana murthy in the late 1970s, provided 10,000 of her savings as seed capital and supported her husband in the early days of Infosys (founded 1981).

Her contribution as a prolific writer with over 40 books in Kannada and English, prominent titles include Dollar Bahu, Wise and Otherwise, Grandma's Bag of Stories, Three Thousand Stitches. Her Dollar Bahu was adapted into Zee TV series (2001) and many.

Infosys Foundation (Est 1996) under the leadership the foundation built thousands of households (2,300), Libraries (70,000) and Toilets (16,000).

She got Padma Shri, 2006 and Padma Bhushan, 2023 for her social work and



literacy contributions, she also nominated as member of Rajya Sabha. Sudha Murthy's journey spans engineering literature, philanthropy and public service, her values of simplicity, education, empathy and women's empowerment have made lasting impact through her books, the Infosys foundation's transformative project and how her role in Rajya Saba also sharing insights on balance between passion driven work and career success.

**“DOING WHAT YOU LIKE IS FREEDOM,
LIKING WHAT YOU DO IS HAPPINESS”**

Artificial Intelligence – The Invisible Engine of Tomorrow

In recent years, Artificial Intelligence (AI) has become more than just a buzzword it is silently transforming every part of our world, from healthcare and finance to education and entertainment. But what exactly is AI, and why does it matter so much today?

Artificial Intelligence is the ability of machines to perform tasks that typically require human intelligence. This includes understanding language, recognizing patterns, solving problems, learning from data, and even making decisions. AI systems are powered by algorithms, data, and computing power, and they improve through a process called machine learning.

You might not realize it, but AI is already part of your daily life:

- Smartphones use AI for voice assistants, face recognition, and photo enhancements.
- Streaming services recommend your next movie using AI algorithms.
- Banks detect fraud by analyzing spending patterns.
- Healthcare uses AI to diagnose diseases, interpret scans, and personalize treatment.
- Even in education, AI is helping personalize learning, create intelligent tutoring systems, and automate administrative tasks.

The Ethical Side of AI

With power comes responsibility. As AI systems become more powerful, they raise serious ethical questions: Can machines be biased? Yes. AI learns from data, and if the data is biased, so will the outcomes.

Will AI take away jobs?

It might automate some roles, but it will also create new ones that require creative thinking and human judgment.

The Future of AI

The future of AI is not just about robots or sci-fi. It's about real-world improvements smart cities, better healthcare, safer transportation, and efficient industries. AI will work with humans, not against them, amplifying our abilities and unlocking new possibilities. Certainly! Here's an extended version of the AI article, expanding on its types, real-world applications, future trends, and opportunities for students. You can use this for a college magazine, seminar,

blog, or presentation.

Why Students Should Learn AI

For MCA Students:

Explore careers in AI development, data science, machine learning, cybersecurity, and robotics.

Learn programming languages like Python, use frameworks like TensorFlow and scikit-learn, and work with datasets.

Build projects like AI chatbots, recommendation systems, face recognition apps, or fraud detectors.

For MBA Students:

Use AI tools in data-driven decision making, digital marketing, HR analytics, and customer relationship management (CRM). Understand how AI transforms supply chain management, finance forecasting, and business strategy.

Learn how to manage AI adoption in organizations, balancing technology with ethical and human aspects.

Conclusion:

Artificial Intelligence isn't just about machines it's about human potential amplified by technology. As students, our job is to learn, adapt, and contribute responsibly. Whether you're developing the next AI tool or making business decisions based on AI data, your knowledge today will shape tomorrow's world.

"AI is not the future it's the present with the power to change the future."

VVignesh S
4AD24MC086
2nd sem MCA 'B'



The Digital Generation: Are We Evolving or Escaping?

We are called the “Digital Generation”, born in an era where information is instant, everything is online, and the internet feels like a second home. Technology is our daily companion, from alarms that wake us up to playlists that help us sleep. We attend online classes, connect through social media, learn from AI tutors, and even express our emotions through gifs and emojis.

But as a student, I've started asking myself something deeper:

Are we truly evolving with technology, or are we slowly escaping into it?



Technology: The Power of Evolution

There's no denying that technology has transformed education and everyday life. We now learn beyond textbooks through videos, simulations, AI chatbots, and digital platforms. Subjects that once seemed boring now come alive on screen. We collaborate on Google Docs, attend Zoom lectures, and clear doubts instantly on apps like ChatGPT.

Learning is no longer limited to the four walls of a classroom. A student in a small village can learn coding, foreign languages, or even astrophysics just with a mobile phone and the internet. That's not just development. That's evolution.



And it's not just learning creativity that has evolved too. Today, students can build websites, create music, edit videos, start podcasts, and design graphics often for free. Technology has given us wings to fly beyond traditional limitations.

Even emotionally, we are more open than ever posting thoughts, seeking help, sharing mental health experiences online. These are signs of a generation that's evolving to be expressive, smart, and connected.

The Hidden Side: Escaping Reality

Technology has become our escape button. When we're stressed, we scroll. When we're lonely, we post. When we're anxious, we binge-watch. When we fail, we distract ourselves with endless memes, videos, or reels. I've done this too. There have been

There have been times when I felt overwhelmed with studies or personal issues and instead of facing them, I just plugged in my earphones and escaped. No



solutions, j u s t temporary numbness.

What began as a five-minute break often turned into two hours of scrolling. And when I looked up, the real world still waited only now with more anxiety, more guilt, and less time.

So, Are We Evolving or Escaping?

The truth is we are doing both. And that's okay, as long as we're aware of it. Evolution means using technology to grow, learn, connect, and express ourselves in healthy ways. Escaping means using it to avoid, numb, distract, or run away from problems we need to face. Both may look the same on the outside. But they feel very different on the inside.

Think about this:

- Watching a tutorial to understand a tough subject = evolving
- Watching 50 random videos to avoid studying = escaping
- Posting a creative reel to share your dance talent = evolving
- Posting selfies to seek validation and feel “enough” = escaping

As students, we walk this fine line every day.

The Digital Mindset We Need

Technology is not good or bad. It's a mirror that reflects how we use it. We need to develop something I call a “digital mindset”:

- Use the internet to learn, not just to scroll
- Create more than we consume
- Rest without guilt, but escape with awareness
- Replace mindless scrolling with mindful choices

If we're intentional, we can use tech to become better learners, better creators, and better humans.



Anlee Preethi
4AD24MC008
2nd sem MCA 'A'

Cybersecurity: The Invisible Shield of the Digital Age

In a world where we are constantly connected scrolling through social media, making online payments, working on cloud platforms, and storing personal memories in digital vaults cybersecurity stands as the unseen guardian. Without it, our digital lives would be vulnerable to prying eyes, malicious attacks, and devastating breaches. But what is cybersecurity really, and why has it become one of the most critical concerns of our era?

What is Cybersecurity?

Cybersecurity refers to the practice of protecting systems, networks, and data from digital attacks. These attacks are aimed at stealing, damaging, or disrupting information or services. Think of cybersecurity as the seatbelt and the airbag of your digital vehicle may not see it working all the time, but when danger strikes, it's the difference between safety and disaster.

The Threat Landscape

- **Phishing:** Fake messages designed to steal your credentials.
- **Ransomware:** Malware that locks data until a ransom is paid.
- **Zero-day attacks:** Exploits that hit before developers can patch flaws.
- **DDoS (Distributed Denial of Service):** Overloading servers to bring down services.
- **Social engineering:** Manipulating people into giving up confidential data.

Even the most secure organizations can be victims and their stories serve as valuable lessons.

Famous Cybersecurity Breaches

Yahoo (2013–2014)

One of the biggest data breaches ever, affecting all 3 billion Yahoo accounts. Hackers stole names, email addresses, security questions, and passwords showing how critical password security and encryption are.

WannaCry Ransomware Attack (2017)

A global ransomware attack that impacted over 200,000 computers in 150+ countries, including hospitals in the UK, forcing cancellations of surgeries and medical services.

Facebook-Cambridge Analytica (2018)

Not a breach in the traditional sense, but a data privacy scandal where the personal data of millions of users was harvested and misused for political purposes - highlighting the importance of data governance.

Colonial Pipeline (2021)

A ransomware attack that disrupted fuel supply across the US East Coast, leading to fuel shortages and panic buying. This was a wake-up call about vulnerabilities in critical infrastructure.

The Warriors of the Cyber World

Behind the scenes, cybersecurity professionals work tirelessly:

- **Ethical Hackers (White Hat Hackers)** - they break into systems (legally!) to find weaknesses before the bad guys do.
- **Incident Responders** - they swoop in during or after an attack to contain damage and restore systems.
- **Threat Analysts** - they study hacker tactics to predict and block future attacks.

Fun fact: Many large companies (like Google, Microsoft, and Facebook) run bug bounty programs, paying hackers thousands of dollars for finding security holes!

Tips to Strengthen Your Cyber Hygiene

- Use strong passwords: Make them long (12+ characters), mix letters, numbers, and symbols. Never reuse passwords.
- Enable two-factor authentication (2FA): Even if a hacker has your password, 2FA adds another barrier.
- Be cautious of links: Phishing emails often look real - always verify before clicking.
- Update software regularly: Updates patch security holes that attackers exploit.
- Back up data: Use secure cloud services or external drives so you can recover files if attacked.
- Use antivirus and firewall protection: These provide basic shields against common threats.

The Future of Cybersecurity

Entering an era of hyperconnectivity:

Smart cities

Autonomous vehicles

IoT-connected medical devices AI-powered systems

Cybersecurity will evolve to protect not just data, but lives. And with quantum computing on the horizon, today's encryption methods will need to be reimagined entirely.

My Thoughts

Cybersecurity is no longer an option - it's essential. From individuals to governments, we must all play a part. Stay informed. Stay alert!

Always remember: in the digital world, security begins with you.



Priyanka R
4AD24MC061
2nd sem MCA 'B'

Robotics: Engineering Intelligence into Machines

Introduction

Robotics is a multidisciplinary field that combines artificial intelligence (AI), computer science, engineering, and mathematics to design, build, and operate robots. A robot is a machine that can perform tasks autonomously or semi-autonomously, often mimicking human actions. Robots can be programmed to perform a wide range of tasks, from simple repetitive tasks to complex tasks that require decision making and problem-solving.

What Is Robotics?

Robotics is a branch of engineering that combines mechanics, electronics, and computer programming to create machines that perform tasks automatically or with guidance. These machines are called robots.

How Do Robots Work?

Every robot has five key parts:

- Sensors – Like eyes and ears, they help robots "sense" the world.
- Actuators – Motors and wheels that make the robot move.
- Controller – The robot's brain that makes decisions.
- Power Source – Usually batteries or electricity.
- Software – Code that tells the robot what to do.

Types of Robots

- Industrial Robots – Automated arms in factories for welding, painting, or assembly.
- Medical Robots – Used in surgeries (e.g., da Vinci system), rehabilitation, and diagnostics.
- Service Robots – Includes cleaning robots (like Roomba), delivery bots, and customer service assistants.
- Exploration Robots – Deployed in extreme environments such as deep oceans or outer space (e.g., NASA's Perseverance rover).
- Humanoid Robots – Robots that mimic human appearance and behaviour (e.g., Sophia, Atlas).

Where Are Robots Used?

Robots are everywhere:

- Manufacturing: Robotics is widely used in manufacturing for tasks such as assembly, welding, and material handling. Robots can improve efficiency, productivity, and safety in manufacturing environments.
- Healthcare: Robotics is used in healthcare for tasks such as surgery, patient care, and rehabilitation. Robots can improve patient outcomes and reduce the risk of complications.
- Transportation: Robotics is used in transportation for tasks such as self-driving cars and drones. Autonomous vehicles can improve safety and efficiency in transportation systems.
- Service: Robotics is used in service industries such as customer support, education, and hospitality. Robots can improve customer experiences and provide personalized support.

Robots & Artificial Intelligence

Modern robots use AI (Artificial

Intelligence) to:

- Perception – “Seeing” the World, helps robots understand their surroundings through sensors, cameras, and Microphones.
- Decision Making – “Thinking” Before Acting, AI enables robots to analyse data and make smart decisions rather than relying on rigid programming.
- Learning – Getting Smarter Over Time, Using machine learning, robots can learn from past experiences to improve improvements.
- Natural Language Processing – Understanding Human Speech, AI allows robots to listen, interpret, and respond to human voice commands.
- Motion and Control – Moving Intelligently, AI controls the movement and coordination of robotic limbs or wheels with Precision.
- Emotion and Interaction – Human-like Behaviour, Advanced AI lets robots recognize emotions and interact with humans socially.

Robotics Technology

Robotics technology has advanced significantly in recent years, with Improvements in areas such as:

- Artificial Intelligence (AI): AI is a key component of robotics, enable robots to make decisions and learn from experience. AI algorithms can be used for tasks such as object recognition, speech recognition, and decision-making.
- Machine Learning: Machine learning is a type of AI that enables robots to learn from data and improve their performance over time. Machine learning algorithms can be used for tasks such as object recognition, grasping, and manipulation.

- **Computer Vision:** Computer vision is a field of study that enables robots to interpret and understand visual data from cameras and other sensors. Computer vision algorithms can be used for tasks such as object recognition, tracking, and navigation.
- **Sensors and Actuators:** Sensors and actuators are critical components of robotics, enabling robots to perceive and interact with their environment. Sensors can provide data on temperature, pressure, and other environmental factors, while actuators can be used to control movement and action.

Future Trends in Robotics

As the field evolves, here are key trends shaping the next generation of Robotics:

- **Collaborative Robots (Cobots):** Designed to work safely alongside humans in shared spaces.
- **Soft Robotics:** Flexible robots inspired by biological organisms.

- **Swarm Robotics:** Coordinated behaviour among multiple simple robots, like bees or ants.
- **Neuro-Robotics:** Robots that interact with the human brain, used in prosthetics and therapy.
- **Robots as Companions:** In elder care, education, and emotional support.

Conclusion

Robotics is no longer a niche discipline it's a transformative force impacting every industry and aspect of life. As technology continues to advance, robotics will play an even greater role in solving real-world problems, enhancing human capabilities, and unlocking new frontiers of innovation.



Pushpa S
4AD24MC062
2nd sem MCA 'B'

AI-Generated Code: Will Developers Become Architects Instead of Coders?

Introduction: A New Era of Software Development

The rise of artificial intelligence is reshaping industries faster than ever before. Among the most impacted fields is software development, where AI-generated code is emerging as a transformative force. Imagine a world where developers no longer spend

hours writing boilerplate code, but instead focus on designing intelligent systems while AI handles the heavy lifting.

This shift sparks big questions: Will the traditional act of coding become obsolete? Are we witnessing the dawn of a new kind of developer one who architects intelligent solutions instead of crafting each line manually? Let's explore how AI-generated code is changing the way we build software and what it means for developers moving forward.

The Changing Role of Developers

As AI continues to evolve, developers are beginning to shift from hands-on coders to high-level strategists. With AI tools capable of generating, testing and even refactoring code, many of the routine tasks that once consumed hours can now be completed in minutes.

This doesn't mean developers are being replaced. Instead, their roles are becoming more creative and strategic. Rather than focusing on syntax and structure, they are tasked with designing user-centered experiences, defining system architecture and aligning software solutions with business objectives.

Collaboration with AI will be central. Developers will become curators guiding, refining and validating AI-generated outputs to ensure they meet the specific needs of a project. In this new paradigm, titles like "Code Architect" or "AI Development Strategist" may become commonplace, reflecting the deeper, more analytical responsibilities of modern developers

Advantages and Challenges of AI-Generated Code

The benefits of AI-generated code are clear. Speed is perhaps the most compelling advantage. AI can produce functional code in seconds, significantly accelerating the development life cycle. This allows teams to prototype rapidly, iterate faster and bring products to market more efficiently.

Error detection also improves. AI tools are increasingly adept at identifying bugs and suggesting fixes — sometimes even before the human eye catches them. This leads to

cleaner, more reliable code, improving the overall quality of software.

But there are challenges too. Relying heavily on AI could lead to skill atrophy among developers, particularly those early in their careers. If coders don't practice foundational skills, their ability to troubleshoot or write optimized code independently may decline. Moreover, AI doesn't always generate perfect solutions. The output can be generic, poorly optimized, or misaligned with business logic. Human oversight remains critical. Developers must continue to learn, adapt and take responsibility for the quality and ethics of the final product.

Transforming the Industry: Faster, Smarter, More Accessible

AI-generated code could revolutionize the software industry as a whole. By automating repetitive tasks, development becomes not only faster but also more accessible. Individuals with limited coding backgrounds could soon build apps using natural language prompts dramatically lowering the barrier to entry.

Startups and small teams may benefit the most, being able to produce robust software without the need for large development departments. Larger organizations, on the other hand, may use AI to streamline operations and scale more efficiently.

But there's also a potential downside: job disruption. As more of the coding workload is automated, traditional developer roles could become less relevant especially those focused on routine tasks. This makes adaptability a key trait for any developer looking to remain competitive.

Ethical Considerations in a Machine-Coded World

The use of AI in coding raises important ethical questions. One of the biggest concerns is accountability. If an AI generates faulty code that causes a data breach or system failure, who's responsible the developer, the company, or the AI provider?

Bias is another major issue. If AI models are trained on flawed or biased data, they may reproduce those biases in the code they write especially in areas like algorithmic decision-making or user interactions.

There are also questions around intellectual property. If AI-generated code is based on open-source data or existing frameworks, does it truly belong to the developer? And can companies legally use that code in proprietary systems?

Lastly, transparency remains a challenge. Developers need to understand how AI tools arrive at certain solutions in order to trust and effectively use them. The "black box" nature of many AI models can hinder this trust, especially in critical systems.

The Future Developer: Part Strategist, Part Technologist

Looking ahead, the future developer may not be the one who types out every function but the one who orchestrates intelligent systems. This role requires a deep understanding of software architecture, problem-solving, and user needs paired with the ability to guide and interpret AI-generated output.

New skill sets will emerge. Developers will need to understand how AI models work, how to assess their output, and how to integrate them responsibly into larger systems. Fields like AI ethics, system architecture and human-computer interaction may become central to a developer's toolkit. Far from replacing developers, AI is opening the door to more creative, strategic, and impactful roles. It allows humans to do what they do best think critically, empathize with users, and design with vision.

Conclusion: Embracing the Shift

The world of software development is undergoing a profound transformation. AI-generated code is not just a trend it's a paradigm shift. As machines take over the repetitive aspects of coding, developers have an opportunity to step into more meaningful, high-level roles.

This evolution brings exciting opportunities but also demands a willingness to adapt. Developers who embrace this change by upskilling, staying curious, and learning to collaborate with AI will find themselves not just relevant but in demand.

Ultimately, AI won't replace developers. But it will redefine what it means to be one. The future belongs to those who are ready to build with machines, not in competition with them.

Vignesh S
4AD24MC086
2nd sem MCA 'B'



Internet of Things(IoT)

Introduction:

The Internet of things(IoT) is all about connections. The number of objects and devices being IoT-enabled using connected sensors, processors and transmitters has greatly increased. They not only collect data but communicate and interact with each other, sharing information and helping to create the larger picture that Big Data provides. Also ,they can be used to control conditions in the physical world.



What is IoT?

The Internet of Things(IoT) refers to a network of physical objects, or “things”, that are embedded with sensors, software, and other technologies to connect and exchange data with other devices and systems over internet.

Ex: smart home,wearables like smart watches, industry, healthcare, transportation.

Some devices can be found just about anywhere:

At home: smart devices can turn on the coffee machine when you wake up, lock the doors when you leave the house and put your

favourite music when you get home.

Travelling to work: smart devices can collect data about traffic volumes, so that you can receive alerts warning you of traffic jam and advising you to take different route.

Uses:

Helping with particular tasks:

The IoT can help enable better-targeted working processes. For example:

- The oil and gas industry has been able to build models based on images to improve the precision of exploration for new reserves.
- In the food industry, data about the conditions where product are kept in, can help to decide shelf life of large batches.

Generating efficiencies:

Smart devices can increase efficiency by reducing the use of resources. For ex:

- Using smart energy devices for better energy management in buildings.
- In agriculture, sensors on farmers enable farmers to monitor soil conditions and irrigation levels, optimizing their water and fertilizer use.

Monitoring for potential problem:

Smart devices can give warning from remote locations about security issues, such as open windows.

They can also perform predictive maintenance i.e. using data of an equipment to estimate when it needs maintenance.

Underpinning strategic development:

For ex: in the automotive industry 3D printers enable car designs to be tailored to customer requirements.

Problems:

- **Security** is an important concern, In some instances the consequences of hacking could be life threatening.
- **Privacy and breaching data protection regulations.**
- **Platform fragmentation:** The problem of providing applications that can work with IoT devices that use variety of hardware and software.
- **Long implementation time and cost constraints:** Developments that concentrate too much on the technology. Limitations of the hardware being used by business or the insufficiency of their information system's infrastructure.

Conclusion:

The IoT provides vast networks that are embedded with technologies to connect and

exchange data. The interconnected devices ,ranging from everyday appliances to industrial tools, enable the collection and sharing of data, leading to more efficient and automated system.

Future scope:

IoT applications continue to develop across commercial, infrastructure, Manufacturing and industrial sectors. Also, bright with expanding applications across various industries and a projected surge in spending connections.



Ranjitha N
4AD24MC067
2nd sem MCA 'B'

The Silent Power of Small Habits: Shaping Your Future One Day at a Time

"Success is the product of daily habits not once-in-a-lifetime transformations."

-James Clear

We often look at success as a grand event a moment of achievement where everything changes. But what if success isn't about a single moment at all? What if it lies in the small choices we make every single day?

As college students, we are constantly bombarded with advice: "Work hard", "Think big", "Chase your dreams." While these are inspiring, they often feel overwhelming. The truth is, most of us are just trying to keep up with assignments, exams, friendships, and sometimes even our own expectations. Amid this chaos, we underestimate the power of small habits.

Waking up ten minutes earlier, reading two pages of a book, drinking an extra glass of water, choosing a 10-minute walk over scrolling Instagram these are actions so tiny, they seem insignificant. But when done consistently, they create invisible momentum. Over time, they build discipline, clarity, and self-trust.

Think of your life as a garden. Every small habit is a seed. Some will bloom into strength, creativity, resilience others into distraction or regret. The best part? You're the gardener. You decide what to plant, water, and let grow.

You don't have to change your entire life in a week. Just ask yourself, "What is one small thing I can do today that my future self will thank me for?" It could be finishing a chapter, talking kindly to yourself, or just taking a deep breath in a stressful moment.

Let's stop waiting for motivation to strike. Let's start small. Because in the end, greatness doesn't come from grand gestures it grows quietly, habit by habit, in the background of our ordinary days.

So next time you feel stuck, remember: You're only one small habit away from a better version of yourself

Why Small Habits Matter More Than Big Plans

Most people wait for motivation to strike or for the "perfect time" to start working on their goals. But successful people rely on systems and routines, not willpower.

For example:

A student who reviews class material for 15 minutes daily will outperform someone who crams the night before exams.

Practicing a few coding problems every day builds a stronger foundation than completing 10 in one sitting once a month. Writing one paragraph a day can eventually become a full research paper or business plan. This is called the Compound Effect

small, smart choices, repeated consistently, lead to remarkable results.

Building Small Habits: A Simple Guide

1. Start Tiny – Don't aim to study 5 hours at once. Begin with 10 focused minutes.
2. Attach Habits to Existing Routines – For example, read for 5 minutes after brushing your teeth or revise notes after lunch.
3. Track Progress – Use a simple checklist or app. Seeing progress builds momentum.
4. Be Patient – Results take time. Think in weeks and months, not days.

Real-Life Application for MCA/MBA Students

MCA Students: Spend 15 minutes daily solving coding problems on platforms like HackerRank or practicing SQL queries.

MBA Students: Read one business article or case study daily to stay industry-aware and improve communication skills.

Over months, these small habits sharpen your mind, improve time management, and make you future-ready without burning out.

Your Habits, Your Identity

Every small action is a vote for the type of person you want to become.

Want to be a top developer? Code a little daily.

Want to be a great leader? Reflect, read, and improve your communication daily.

These habits not only improve your skills they shape your character, your confidence, and your career path.

Final Thought

You don't have to be perfect. You just have to be consistent. The magic of small habits lies in their quiet persistence. Day by day, they work silently behind the scenes, preparing you for the moment when opportunity knocks.

So today, do that one small thing because your future self is already thanking you.

Lakshmi P
4AD24MC030
2nd sem MCA 'A'



To My Dear Friend

Like a sun that shines so bright,
Your smile is a light,
Like a diamond that glows so well,
You have always kept me in your
Warm-hearted-shell,
All the troubles that we have come across,
I Promise never to leave your side,

On a dark gloomy night, I promise I will be
Your Moonlight,
You have always listened to my pains,
And sorrows,
At you had always did your tears behind
Your smile,
I see you and want to tell you that
Everything will be fine.
I wrote this poem to thank you for all your
Silent efforts,

"I'm grateful for your support and encouragement ".
Though these lines are short my
Appreciation and love flow with every single word.
My Love for my dear friend will never stop
Because you are dear to me. My Friend



Vignesh S
4AD24MC086
2nd sem MCA 'B'



Someone You Remember

Why is it hard to let you go?
Even though you left us alone....

Are you becoming cold?
As the days getting old?

Don't you need us for who we are anymore?
If you do then, why are you suffering for?

I can't see your face when you awake,
But i know every smile you fake.

If there's a genie who grant me a wish to make,
I'll ask him to relive those memories I'll take.

Nikhitha Lakshman
4AD24MC068
2nd sem MCA 'B'

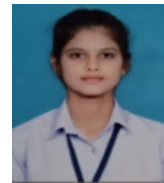

When life smiles back.....!

Hello everyone!

My name is yashwanth A M I am a student of 1st year MCA ATME College .I come from a small town where they don't have the knowledge of education to be honest ,I was never excited about college in the beginning I didn't want to study or sit in the classroom, I know always thought learning was boring but everything changed when I finally joined to this college I made good friends,found teachers who encourage me and offer emotional support, encourage me to pursue my passion, and help to navigate challenges, and discover that learning can actually be fun- especially when it connects to real life.

Now, I enjoy subjects like programming languages, projects and seminars and I've even enjoyed the college for sports like cricket, volleyball. My dream is to become a full stack developer and design technology.

“The magazine is a small step towards sharing my thoughts with every one and I hope you enjoy my reading my journey I believe every student as a unique story and this is just the beginning of mine” .

Thank you.

Yashwant A M
2nd sem MCA 'B'
4AD24MC087



Health & Fitness: Your Real Wealth in a Hectic World

In a world that's constantly chasing deadlines, dreams, and digital distractions, our greatest asset often ends up being the most neglected.



Why Health & Fitness Matter Now More Than Ever

As college students, we're constantly multitasking—balancing classes, projects, friendships, and part-time gigs. In this fast-paced environment, neglecting health can become a dangerous habit.

What we often forget is that health isn't a luxury, it's a foundation. Fitness boosts concentration, improves sleep, uplifts mood, and helps us fight both academic stress and emotional burnout.

Fitness is More Than Just the Gym

Let's break the myth that fitness is only about the gym or six-packs.

Small steps go a long way:

- Use stairs instead of lifts.

- 15 minutes of daily walking or yoga.
- Replace chips with fruits or nuts.
- Hydrate well water over soda.
- Sleep 7–8 hours, especially during exams.
- The goal isn't to be perfect. It's to be consistent.

Mental Health = Fitness Too

Mental fitness is often ignored, but it's just as vital.

- Practice mindfulness or journaling.
- Unplug from social media for a while.
- Reach out to friends or counselors when needed.

Remember: A healthy mind creates a healthier life.



No Time, No Excuses.

Saying “I don't have time” really means “It's not a priority.”

Truth is, even busy students can squeeze in:

- Stretching while watching lectures.
- Walks during calls.
- Deep breathing before sleeping.
- Start with 10–15 minutes daily. That's how strong habits begin.

Your Body Reflects Your Choices

This body will carry you not just through exams, but through life.

- Fuel it. Move it. Rest it.
- Love it not because it looks perfect, but because it's yours.

Conclusion: A Commitment to Yourself

Health isn't about trends. It's about taking small, daily steps to live better, think clearer, and feel stronger.

In a world full of chaos, being healthy is your

quiet rebellion. Start now your future self will thank you.

"Take care of your body. It's the only place you have to live."

- Jim Rohn

Mohammed Affan
2nd sem MCA 'A'
4AD24MC042



The Tech Renaissance – How Engineering is Redefining Modern Civilization

The 21st century marks the dawn of a new renaissance — not of art or literature, but of technology and engineering. Just as the Renaissance era centuries ago redefined human creativity, today's engineers are revolutionizing civilization through innovation, intelligence, and imagination.



This Tech Renaissance is reshaping how we live, work, and connect, creating a future that was once confined to dreams.

The Rise of a New Era

Engineering has always been the foundation of human progress. From the invention of the wheel to the design of spacecraft, engineers have continually pushed boundaries. Yet today's transformation is unprecedented — powered by artificial intelligence, robotics, data science, biotechnology, and sustainable systems. What sets this age apart is the fusion of creativity and computation. Engineers are not just problem solvers; they are creators of experiences, designers of systems, and architects of the future.

Blending the Physical and Digital Worlds

The boundaries between the real and virtual worlds are dissolving. With technologies like the Internet of Things (IoT), virtual and augmented reality, and cyber-physical systems, engineering now bridges human intelligence with machine precision. Smart cities, autonomous vehicles, and intelligent infrastructure are no longer futuristic ideas — they are realities born from engineering innovation. Every click, connection, and circuit plays a part in this vast digital symphony that defines modern civilization.

Sustainability at the Core

Unlike the industrial revolutions of the past, the Tech Renaissance emphasizes sustainability and responsibility. Engineers are rethinking materials, manufacturing, and energy use to create technologies that coexist harmoniously with nature. Solar panels, electric vehicles, green buildings, and waste-to-energy systems are examples of engineering's evolving conscience. Progress is no longer measured by speed or scale alone, but by its impact on people and the planet.

Empowering Humanity through Technology

Engineering is not just transforming industries — it is empowering humanity. Advances in healthcare technology, assistive devices, communication tools, and disaster management systems are enhancing the quality of life for millions. From rural development projects to space exploration, engineering continues to serve as a force for good, bridging inequalities and enabling inclusive growth. The Tech Renaissance is, therefore, not just a celebration of machines, but of human potential amplified by technology.

The Role of Education and Young Minds

At the heart of this revolution lies education. Engineering institutions today are incubators of creativity and innovation. Students are encouraged to question, explore, and invent. The laboratories and classrooms of colleges have become the birthplaces of ideas that could transform the world — from sustainable designs to smart devices. The enthusiasm and curiosity of young engineers symbolize the very spirit of this renaissance — a blend of knowledge, passion, and purpose.

Engineering the Future

The Tech Renaissance reminds us that technology is not an end in itself, but a means to a greater goal — to redefine civilization. The tools may have changed, but the essence of engineering remains the same: to imagine, to design, and to build a better world. The challenges ahead — climate change, resource scarcity, and social inequality — demand innovative solutions that only the collective intelligence of engineers can offer.

A New Dawn

As we stand on the brink of tomorrow, it is clear that this renaissance is not limited to laboratories or industries — it thrives in every curious mind that dares to innovate. The engineers of today are shaping a smarter, sustainable, and more connected world for generations to come.

The Tech Renaissance is not merely a technological transformation; it is a rebirth of human ingenuity — a movement where science meets creativity, and imagination meets impact. Engineering is no longer about fixing problems; it is about creating possibilities — possibilities that redefine what it means to be human in a world powered by innovation.

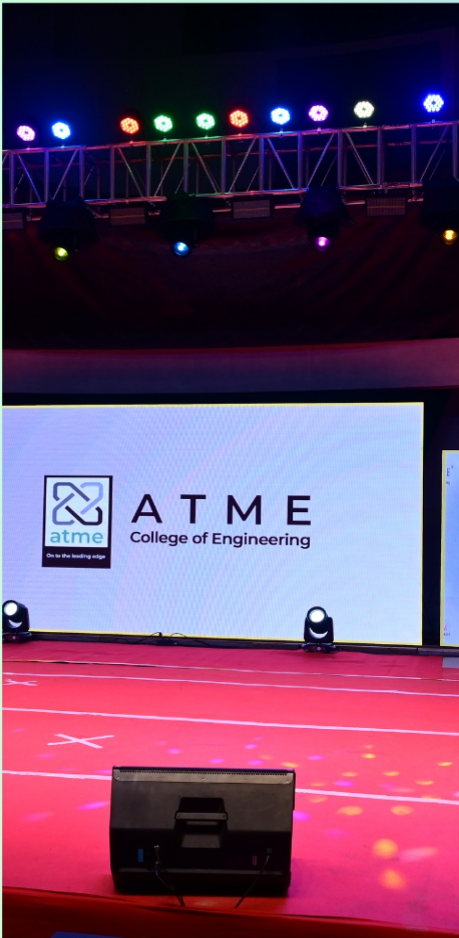









Geetha bai, Department of EC, 6th sem, A section.4AD22EC026

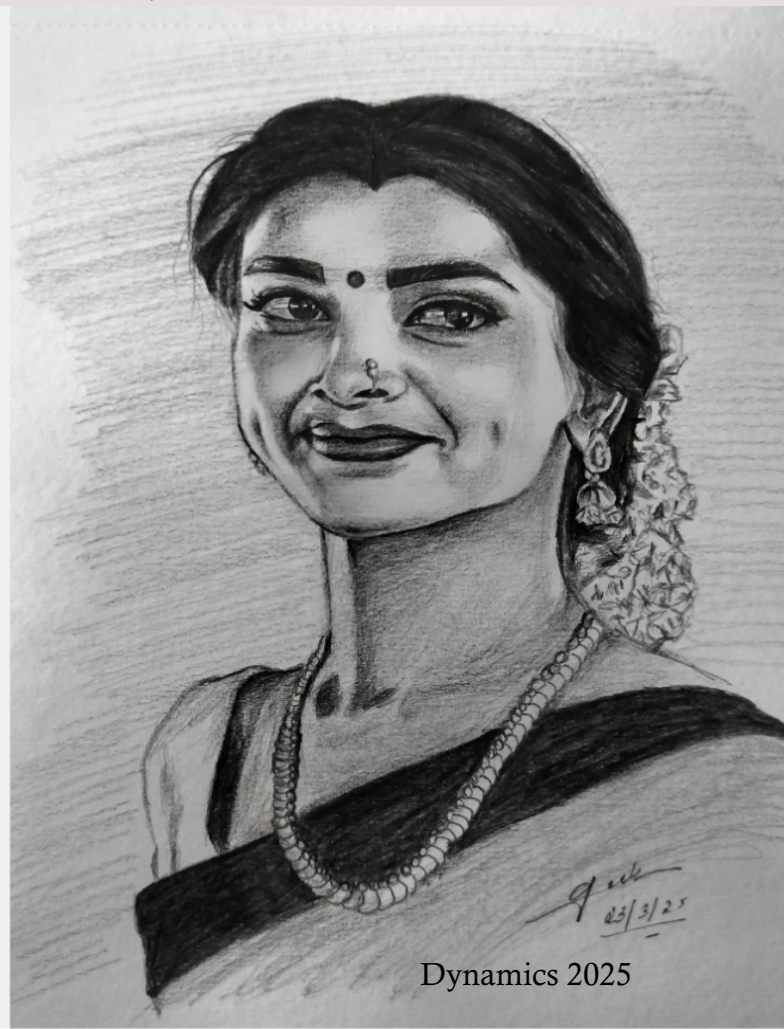



SPOORTHI PN ASST PROF EC

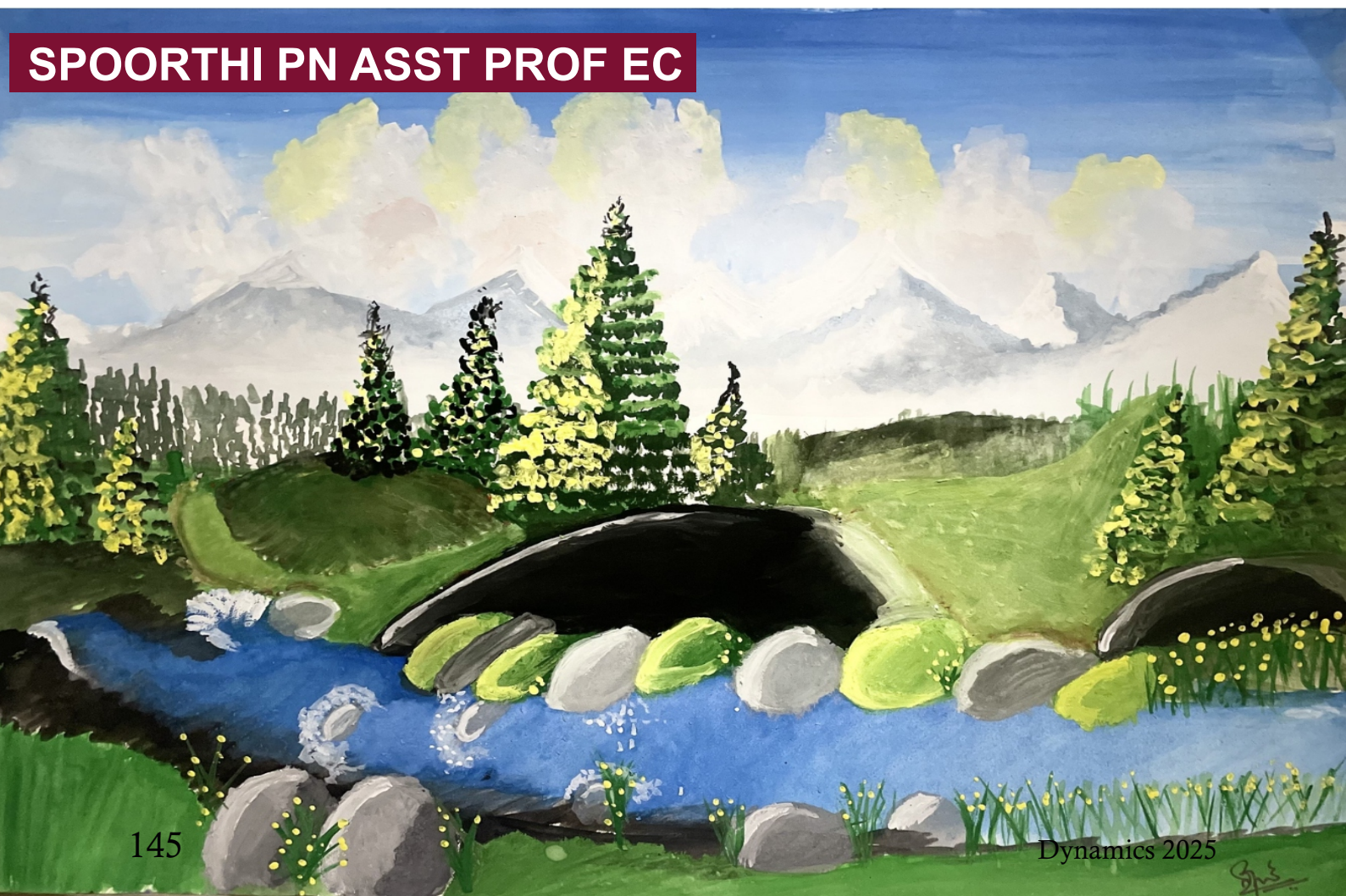



JAYANTH DEVARAJ

Jayanth Devaraj

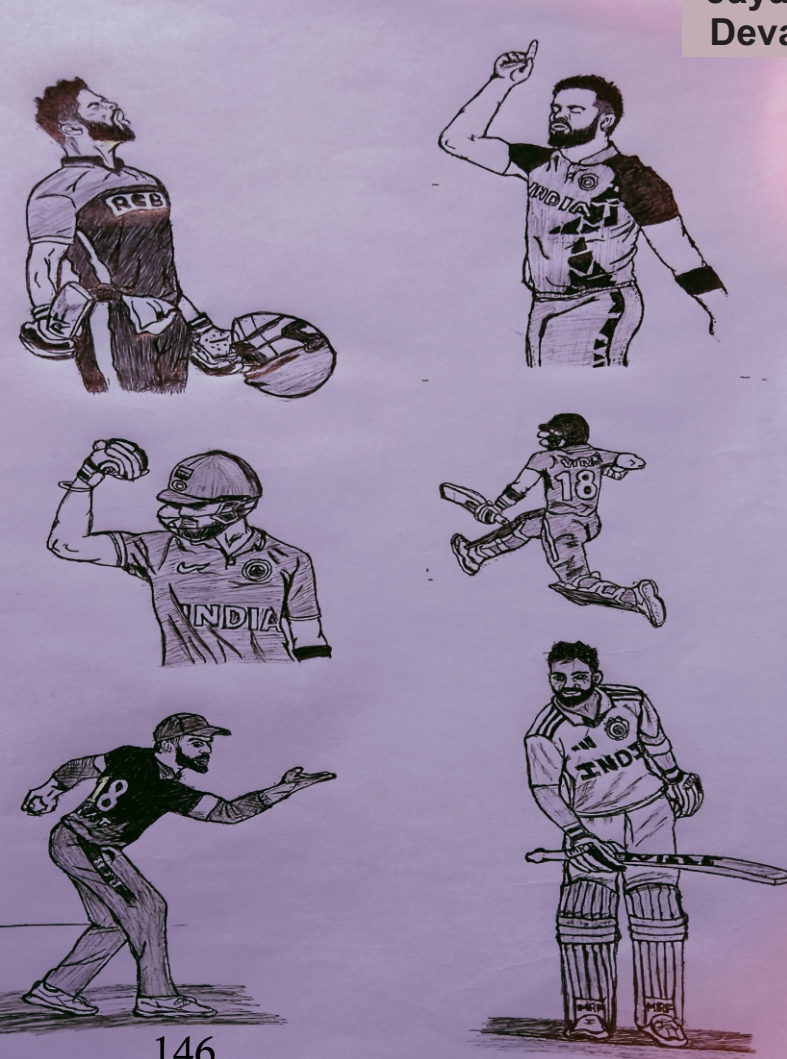

146



ICC WTC FINAL 2023

Dynamics 2025





Chandan H S
EC
8TH SEM

Divya D Seervi,
USN4AD23EC021,
4th Sem, A Section





Madhurya



Mohammed Affan
2nd sem MCA 'A'
4AD24MC042



Umme Hani Sharrif
Assistant Prof
MCA



Mahesh C
2nd sem MCA 'A'
4AD24MC034



Niveditha MM
2nd sem MCA 'B'
4AD24MC053



MAA ♡

Varshini M
2nd sem MCA 'B'
4AD24MC084



**Mohammed
Hasan**
2nd sem MCA 'A'
4AD24MC043



Tanya R
Assistant prof
MCA



Yashwant A M
2nd sem MCA 'B'
4AD24MC087



**Nikhitha
Lakhsman
2nd sem MCA 'B'
4AD24MC051**



**Chandana. S
2nd sem MCA 'A'
4AD24MC014**



**Navya K
2nd sem MCA 'B'
4AD24MC050**

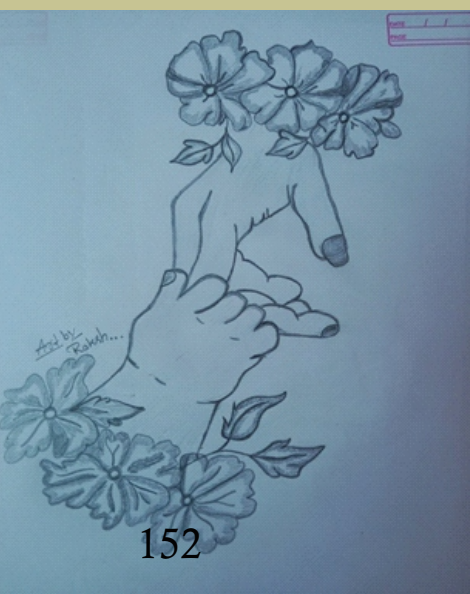

152

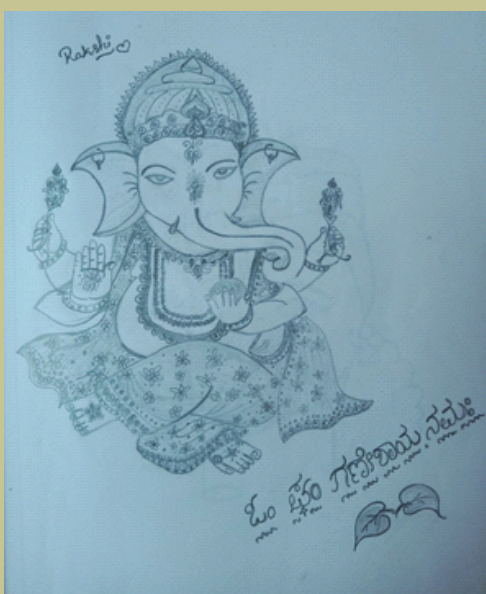

**Rakshitha K C
2nd sem MCA 'B'
4AD24MCO66**



Shreyas B
2nd sem MCA 'B'
4AD24MC076



Ruchitha
2nd sem MCA 'B'
4AD24MC069

Alumni Testimonials

I am truly grateful to have completed my engineering in Electronics and Communication at ATME College of Engineering. The college provided excellent learning opportunities with well-equipped labs and a dedicated VLSI incubation center, where I also completed a VLSI course. Industry experts regularly visited the incubation center to provide us with hands-on training, which strengthened my practical knowledge. I sincerely thank the faculty and lab staff for their constant guidance and support. The environment at ATME was always positive and motivating, helping me grow both technically and personally. I'm thankful to ATME for shaping my career foundation.



Name : Shivu S
Designation: Lead Engineer
Company: PravegaSemi pvt Ltd
Passed out: 2018
ECE alumni



ATME College of Engineering, Mysore, was more than just an academic institution for me. It was a place of growth, learning, and transformation.

The encouragement from faculty and the culture of collaboration across departments created an environment where students were empowered to explore beyond the classroom.

To current and future students: make the most of every opportunity, stay curious, and trust that the foundation you're building here will take you far.

Name : Hemanth J
designation : Technical Sales Engineer at
Hydraquip. Dublin, Ireland
Passed out year : 2023

My four years at ATME College of Engineering were truly transformative. As an ECE student, I was guided by a team of dedicated faculty who consistently motivated us to reach our full potential. I believe the college stands out for its great faculty and good infrastructure. Furthermore, the soft skill and training programs offered were crucial; they genuinely helped us to be industry-ready. These programs, combined with the dedicated efforts of the placement cell, gave me the confidence to be placed in semiconductor industry. I wholeheartedly thank everyone who are part of my ATME journey.



Sukruthi K
Associate Staff Engineer at Samsung
Semiconductor India Research (SSIR),
Bengaluru
Department of ECE
Batch - 2016



“ATME College has been more than just a place to study — it's where I discovered my potential. The encouragement from faculty, hands-on learning, and vibrant campus life pushed me to aim higher every single day. I came in with questions about my future, and I'm walked out with clarity, confidence, and purpose. If you're willing to put in the effort, ATME gives you the platform to rise.”

Name: Sachin Ramesh
Designation: Manager, Analytics Engineering.
Company: GALE
YPO:2016

As a graduating student of the ECE Department at ATME College of Engineering, I am immensely grateful for the transformative experience this institution has provided. The dedicated faculty, well-equipped laboratories, and rigorous curriculum have equipped me with the skills and confidence to excel in the engineering field. The collaborative environment fostered by my peers and mentors made every challenge rewarding. ATME has not only shaped my technical expertise but also instilled a passion for innovation and lifelong learning. Thank you for an inspiring and unforgettable journey!



Chiranth M

ECE DEPARTMENT

ATME College of engineering

Placed at **kryo semi** as an **ASIC engineering with integrated MTECH in VLSI**

Batch : **2025**



"My journey at ATME College of Engineering has been one of growth, discovery, and transformation. As part of the 4th batch, I had the privilege of witnessing the institution's rise from its early years—marked by a strong vision and commitment to quality education. The infrastructure provided by the college and the ECE department was excellent—something that truly set ATME apart even in its early years.

A defining moment in my academic life was the collaboration with VLSI training professionals. The exposure we received through this initiative was a game changer. It not only gave us hands-on experience with industry tools but also shaped our understanding of real-world applications—something that proved to be life-changing for many of us.

ATME laid a strong foundation for both my technical skills and professional mindset. I am proud to be an ATMEian and grateful for the role the institution played in shaping my career."

Anil Kumar

Batch of 2017,

Electronics and Communication Engineering

ATME College of Engineering

Company : **pravegasemi pvt limited**

Designation : **senior lead engineer**

YPO:2016

I'm grateful to have been a part of the Civil Engineering Department at ATME College, graduating as part of the 2023 batch. The department has not only provided strong academic support but also helped me grow professionally and personally.

The faculty members are highly knowledgeable, approachable, and always ready to guide students, whether it's in academics, projects, or career planning. The department offers excellent lab facilities, regular site visits, and hands-on training sessions that bridge the gap between theory and practical learning.

What I appreciated most was the encouragement we received to explore innovative ideas, take part in competitions, and pursue internships. The overall environment is positive, student-friendly, and focused on producing industry-ready engineers.

I will always cherish my time at ATME and remain thankful to the Civil Department for laying a strong foundation for my career.

- AKASH B S, BE Civil Engineering (Batch of 2023)

"Hi, I'm Amrutha M, a civil engineering graduate working as an AI Developer at Wipro. Although my academic background is in civil engineering, I've discovered my passion for AI and technology. My college experience played a significant role in developing my skills and knowledge, which I've successfully applied in my current role. The strong foundation in problem-solving, analytical thinking and adaptability that I gained in college has been instrumental in my transition to AI development. I'm grateful for the opportunities and support that have helped me grow professionally, and I highly recommend my alma mater for its ability to foster diverse skills and interests."

- Amrutha M, BE Civil Engineering (Batch of 2022)

My time at ATME College of Engineering was truly transformative. The rigorous curriculum, coupled with the dedicated faculty, provided me with a strong foundation in Civil Engineering. Beyond academics, the vibrant campus life and numerous extracurricular opportunities helped me develop crucial soft skills like teamwork and problem-solving. I'm grateful for the experiences and education I received at ATME, which have been instrumental in my career success.

- Prajwal R Shekhar, BE Civil Engineering (Batch of 2018)

College Office

ATME College of Engineering
13th Kilometer

Mysuru-Kanakapura-Bengaluru Rd

Mysuru-570028

Ph : +08212954081

<https://atme.edu.in>

Trust Office

#2904(Ch67), II Floor

Kantharaj Urs Rd

Saraswathipuram

Mysuru - 570009

Ph : +08214191551

<https://skilltech.co.in>



+08212593328

Bannur Rd, Mysuru, Karnataka 570028

<https://atme.edu.in>